

# MERKUR

STAVÍME S  JIŽ VÍCE NEŽ 100 LET



Made in Czechia



6.15 KG

421 KS

## ROBOTICKÉ RAMENO 01e

### MANUÁL

ROBOTIC ARM - ROBOTICKÉ RAMENO - ROBOTARM - BRAS ROBOTIQUE - BRAZO ROBOTICO - BRACCIO ROBOTIZZATO - RAMIĘ ROBOTYCZNE  
ROBOTSKA ROKA - ROBOTIKAR - ROBOTARM - ROBOTSKA RUKA - РОБОТИЗИРАНА РАКА - BRAT ROBOTIC - РОБОТИЧНАЯ РУКА

8+

70026

# SPECIFIKACE

## Mechanika

hmotnost stavebnice: 6,15 kg  
maximální dosah ramene: 435 mm  
maximální výška ramene: 599 mm  
maximální rozsah základny: 180°  
rozsah rozevřeného manipulátoru: 40 mm  
materiál: kov + plast

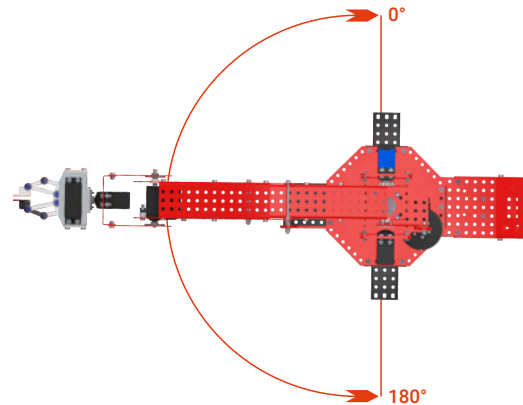
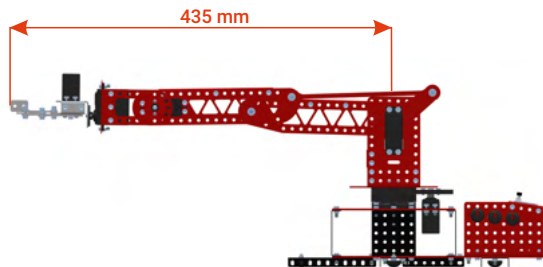

## Elektronika

6x servo motor MG995, kovové převody, 4,5 V - 6 V, 55g/0,18s/15kg/180°  
1x servo motor BH780 - LV200, kovové převody, 4,8 V - 6 V, 60g/0,14s/35kg/200°  
IIC Oled displej 0,96" - bílý, 128x64  
ESP32, ESP32S - 38 pin, Dual-Core 32 bit LX6, WiFi, Bluetooth,  
rozšiřující deska MERKUR Shield pro ESP32  
flash disk  
micro USB kabel A/B  
napájecí adapter 5V 6A

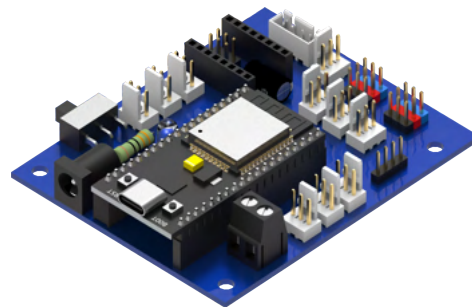

## Software

počítačová aplikace připojena pomocí USB kabelu  
 mobilní aplikace připojena pomocí Bluetooth ( Android )  
 manuální ovládání pomocí potenciometrů  
 vlastní program pro řídicí desku ESP32

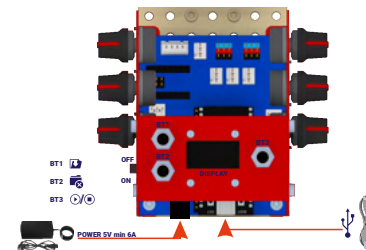

## Použité knihovny

BluetoothSerial.h  
 ESP32Servo.h  
 Wire.h  
 SPI.h  
 Adafruit\_GFX.h  
 Adafruit\_SSD1306.h

## Schéma zapojení pinů

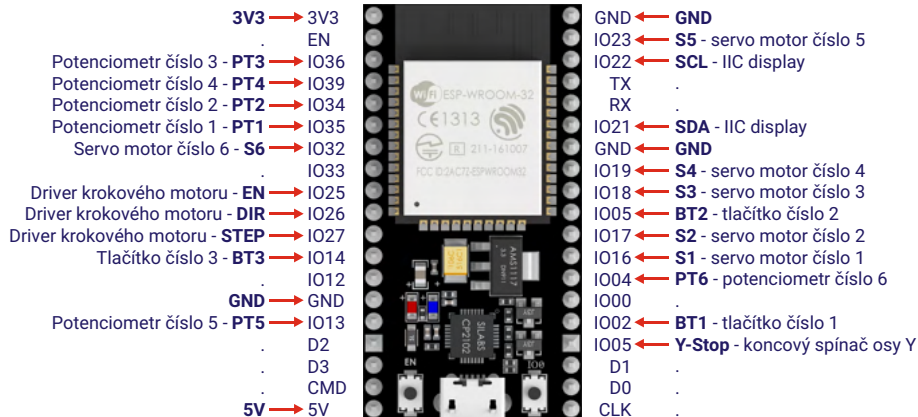

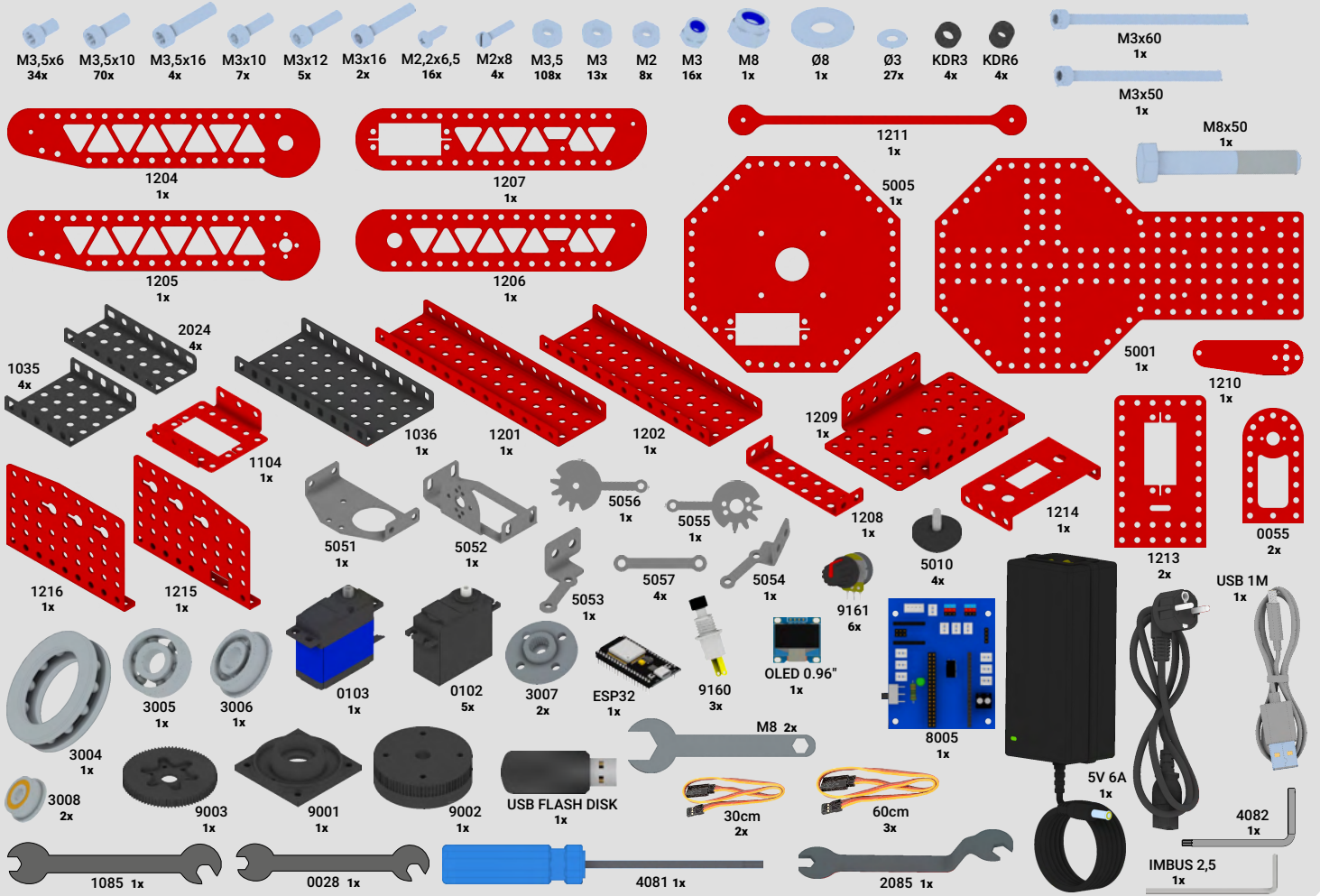

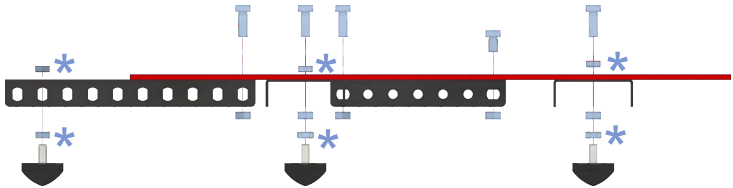
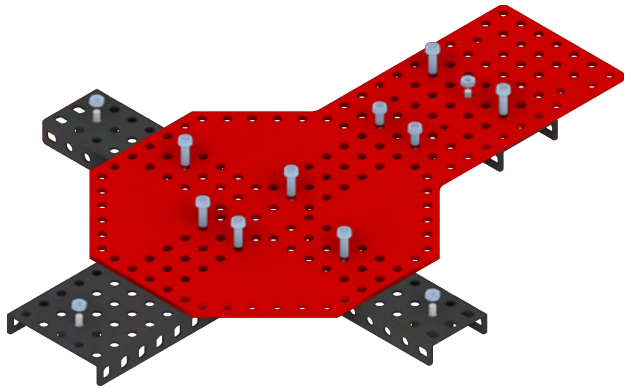
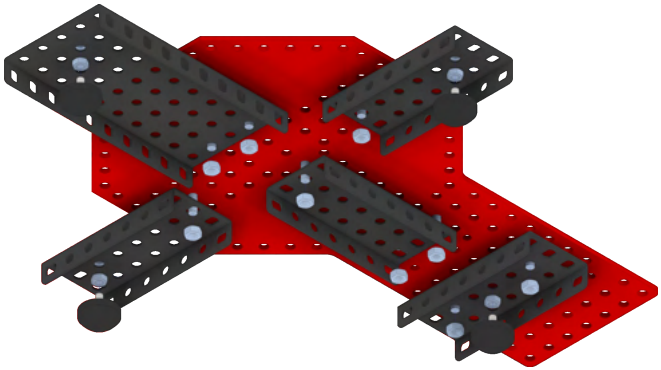
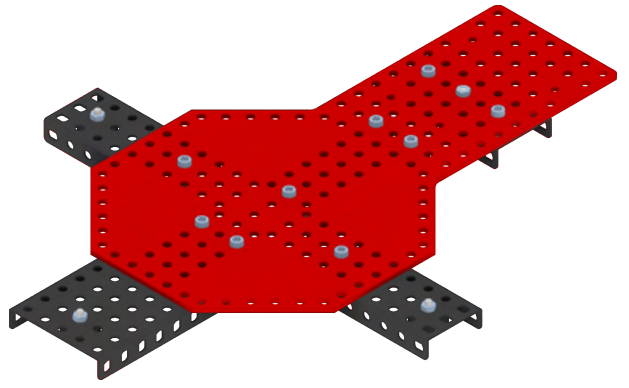
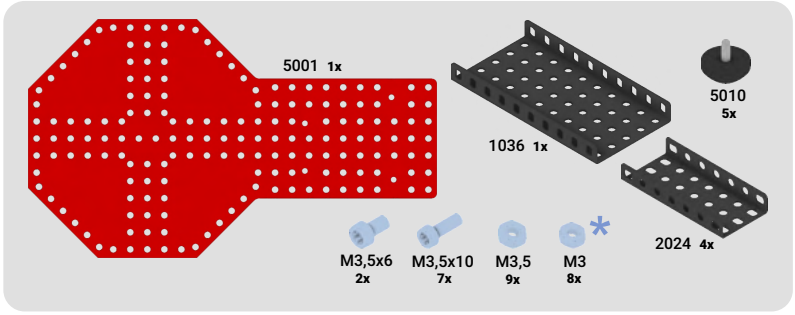

1035 4x

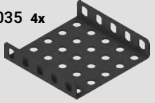

M3,5x10  
9x



M3,5x6  
6x



M3,5  
15x

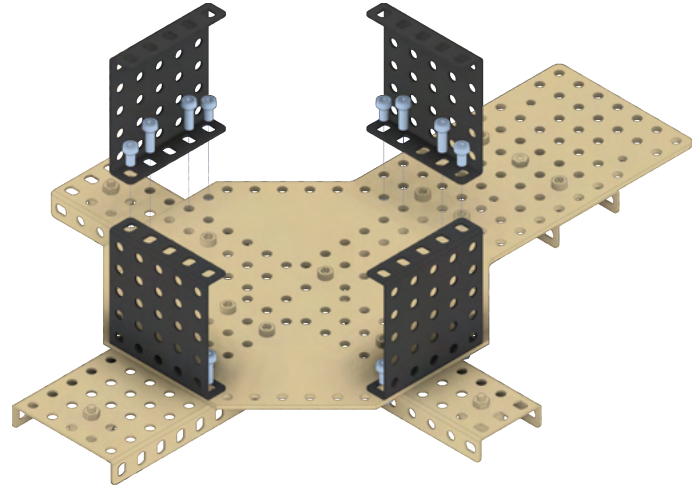
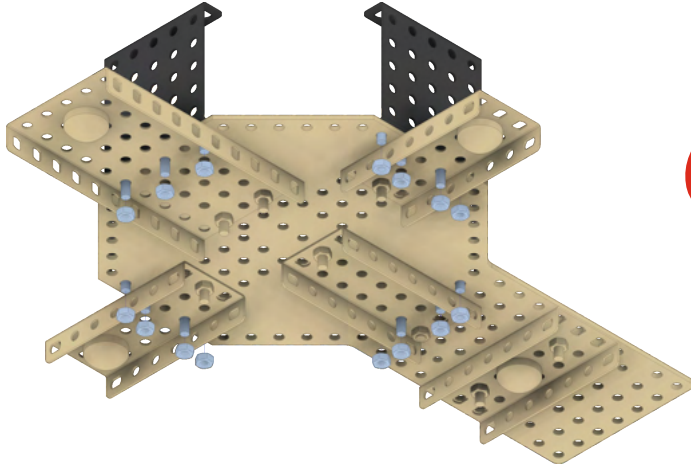
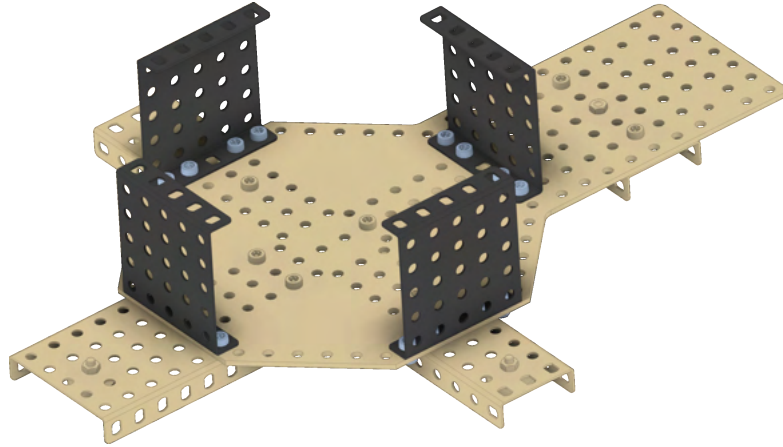

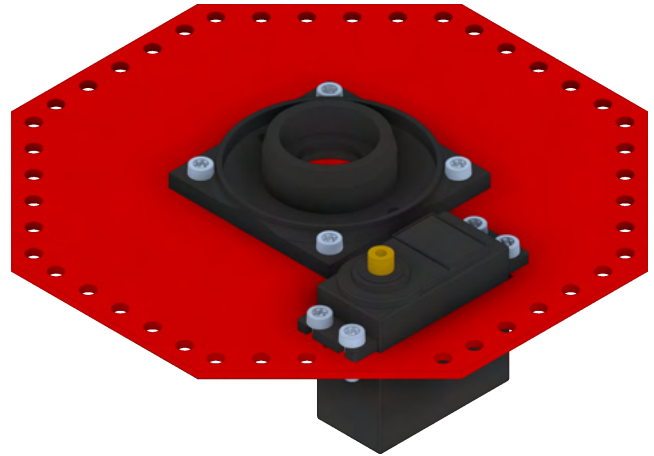
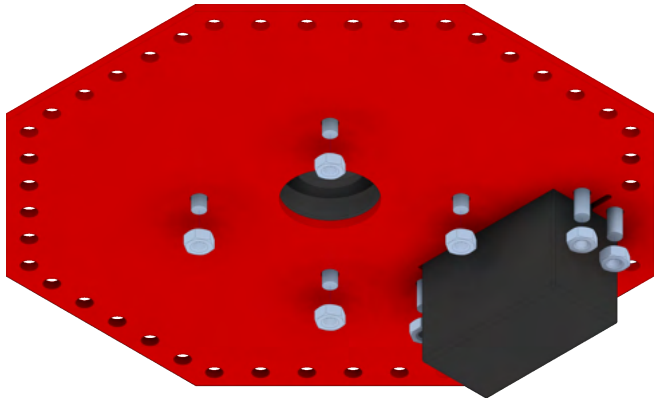
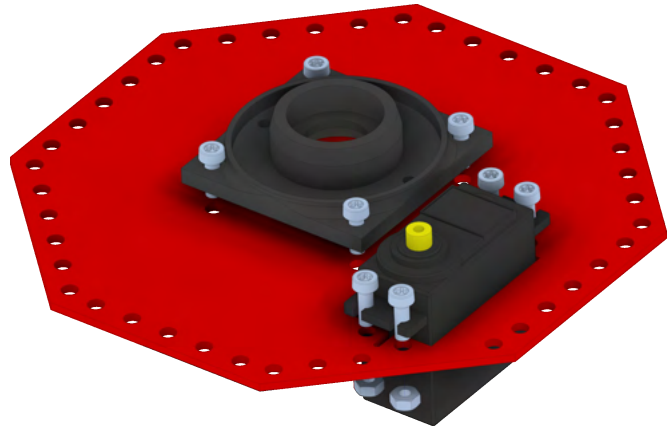
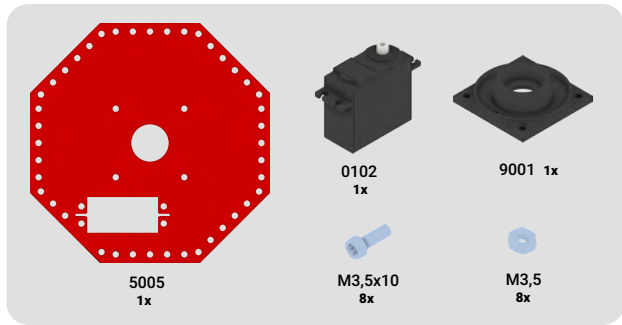

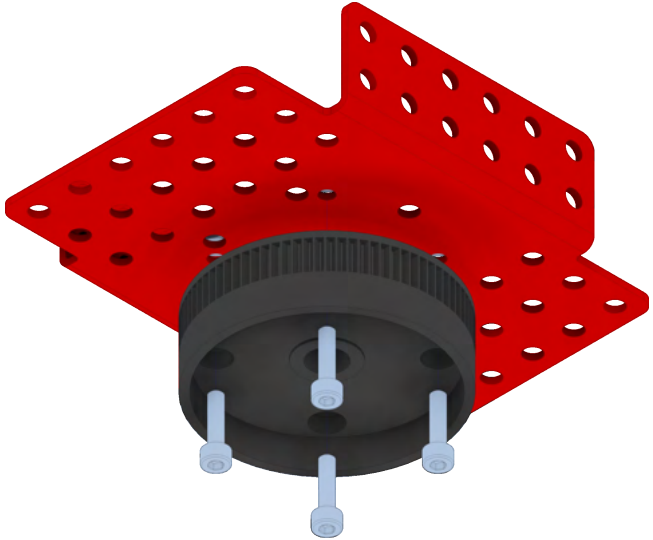
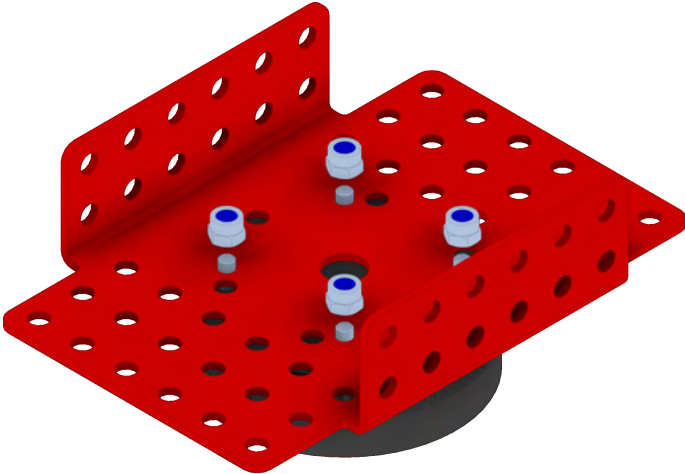
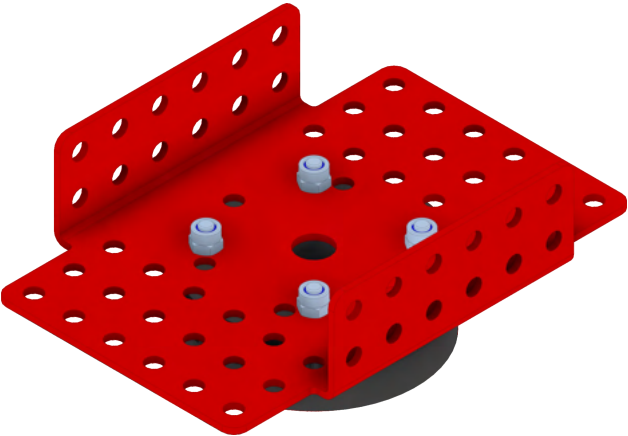
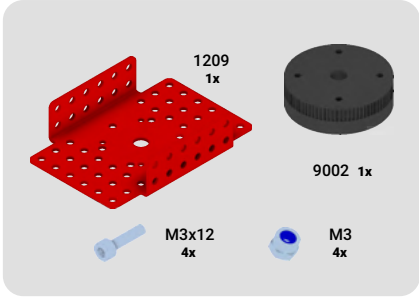

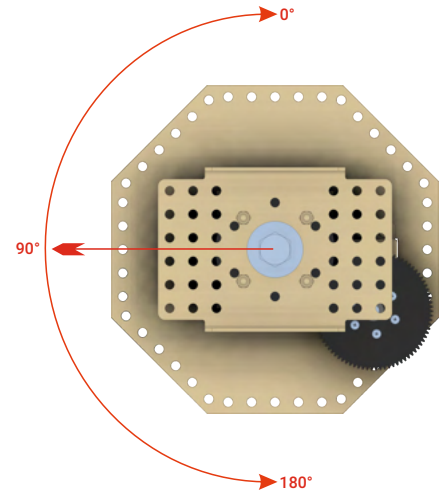
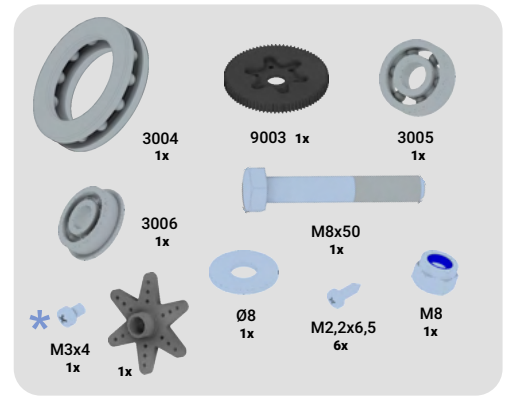
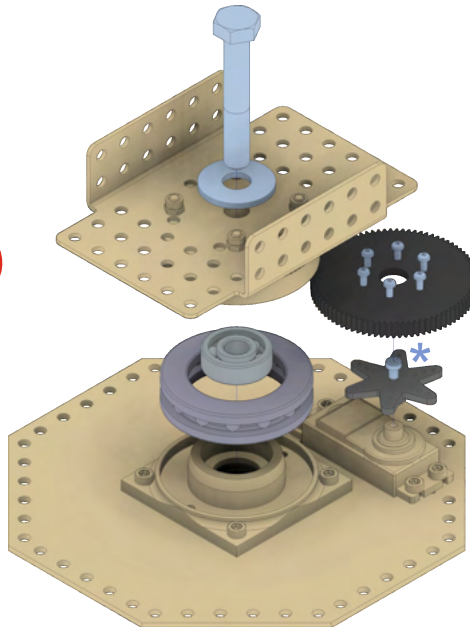
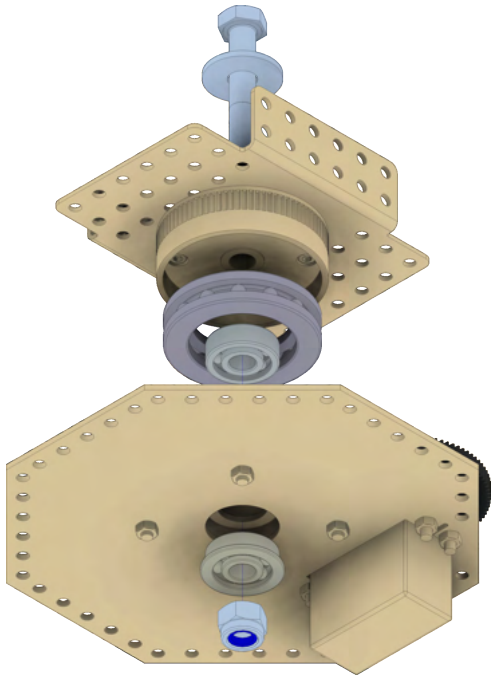

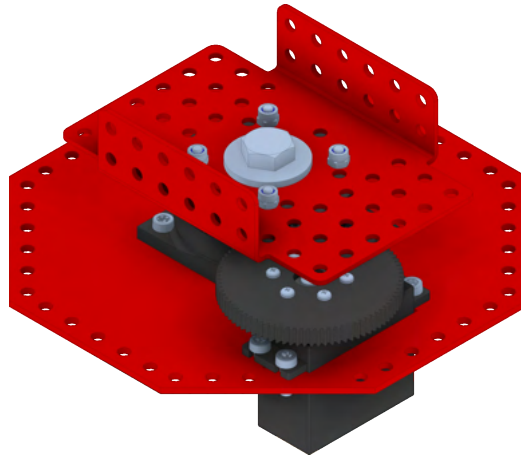
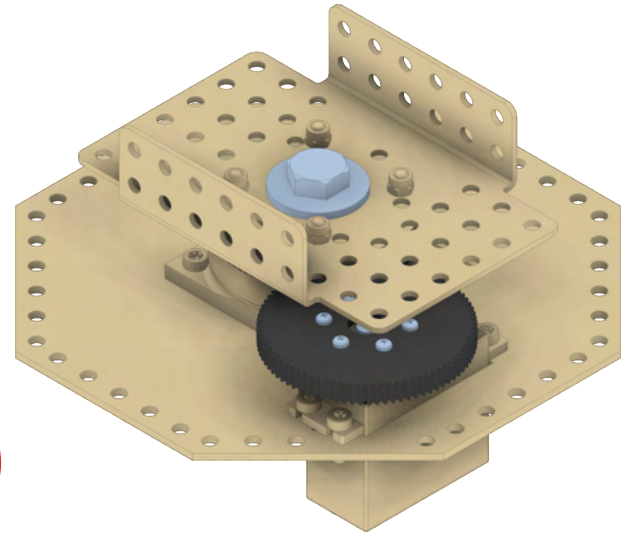
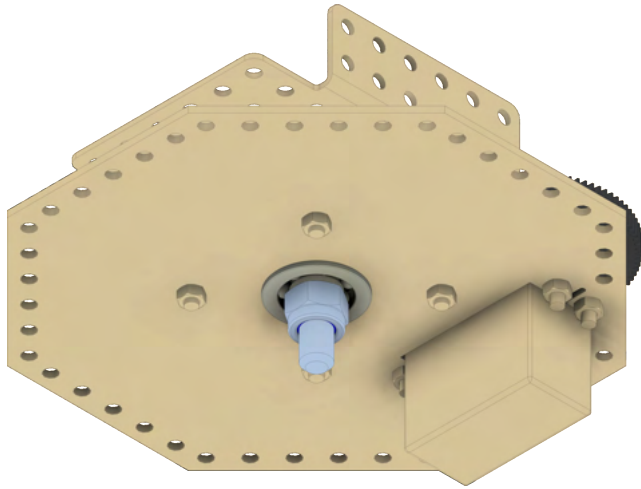

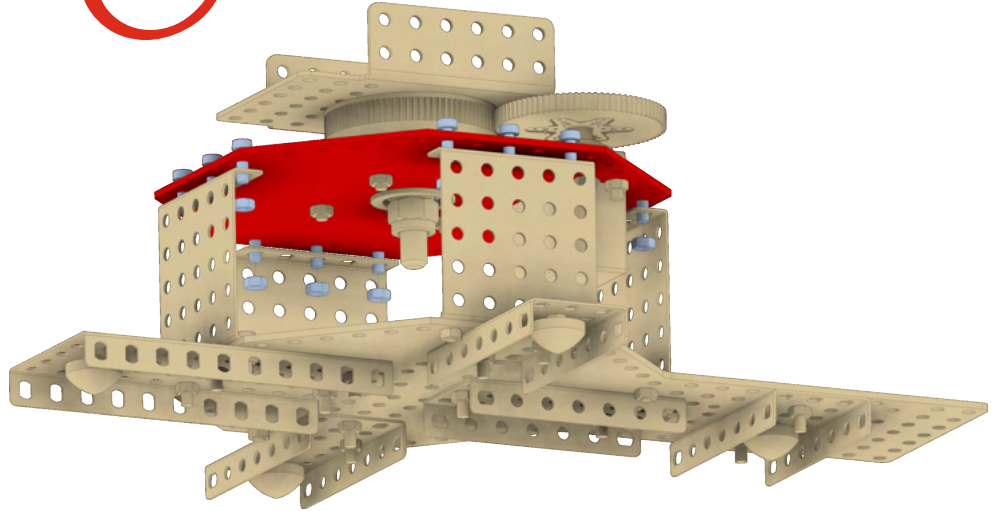
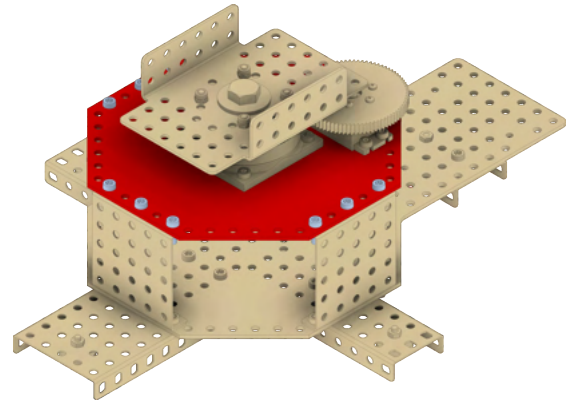
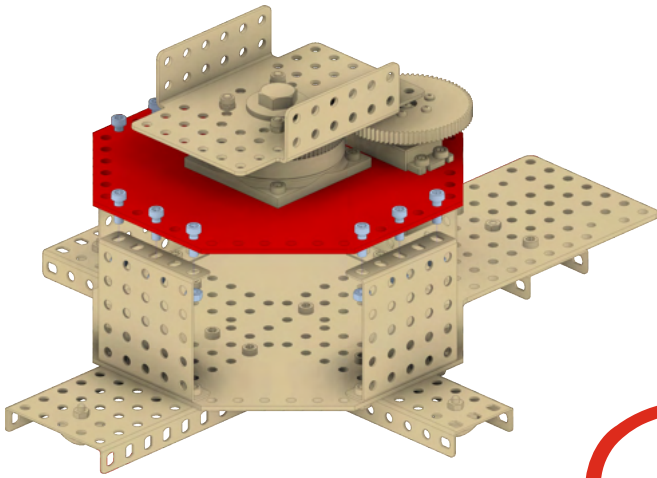

M3,5  
12x



M3,5x10  
12x

1213  
2x

0103  
1x

1208  
1x

M3,5x10  
10x

M3,5  
10x

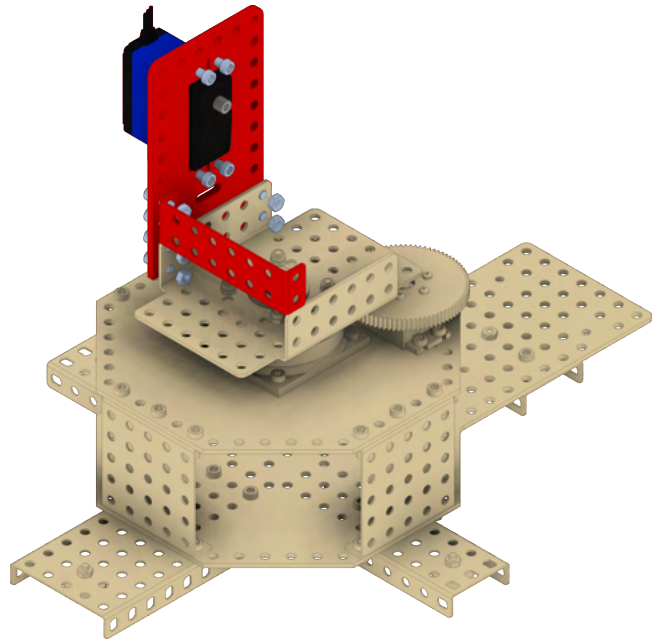
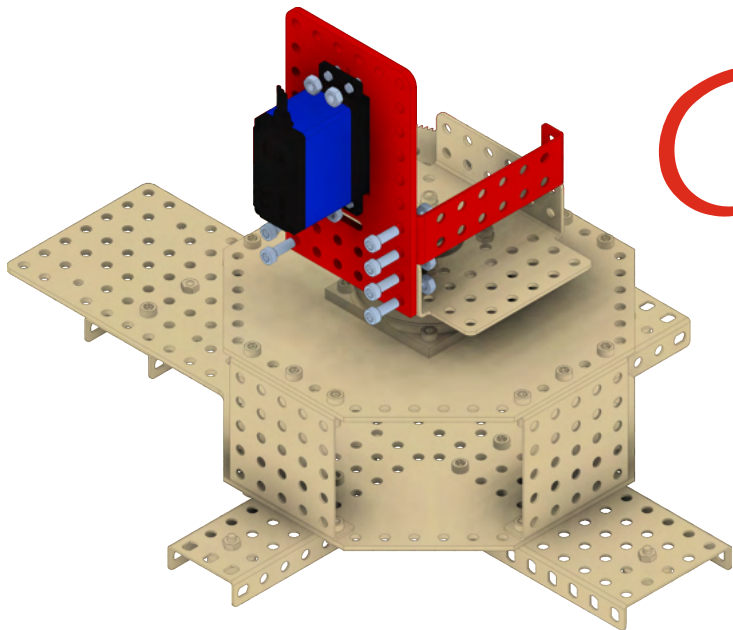

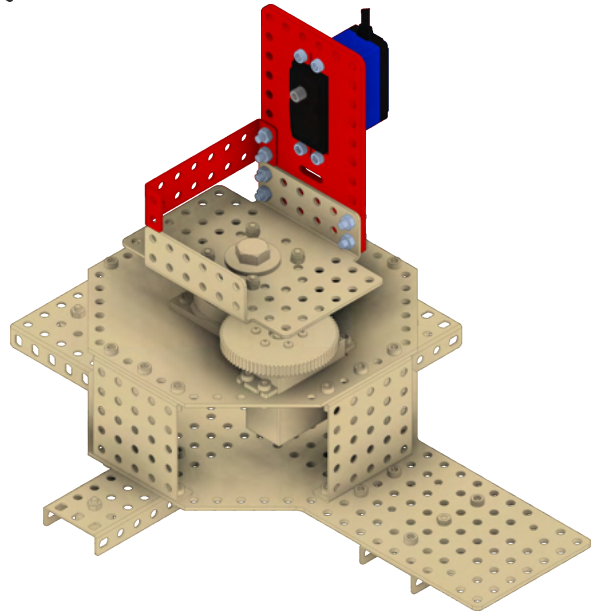
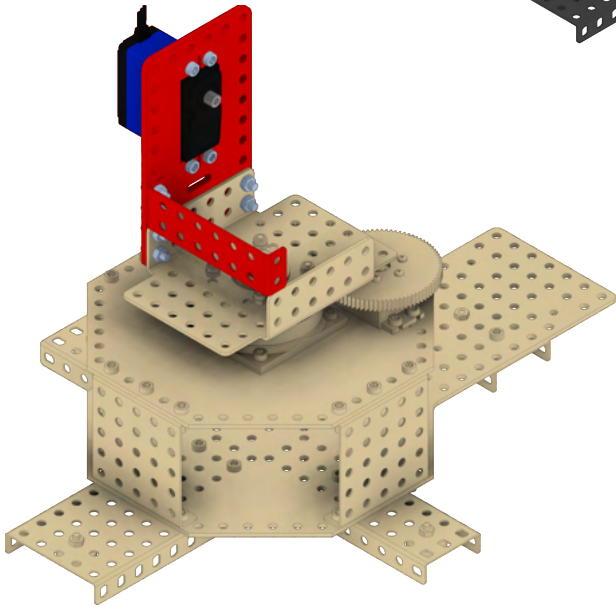
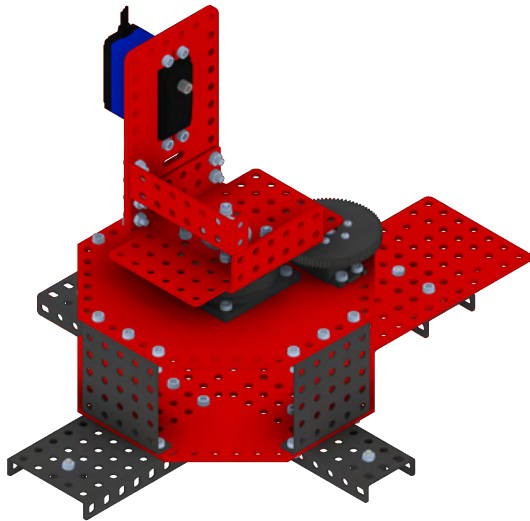

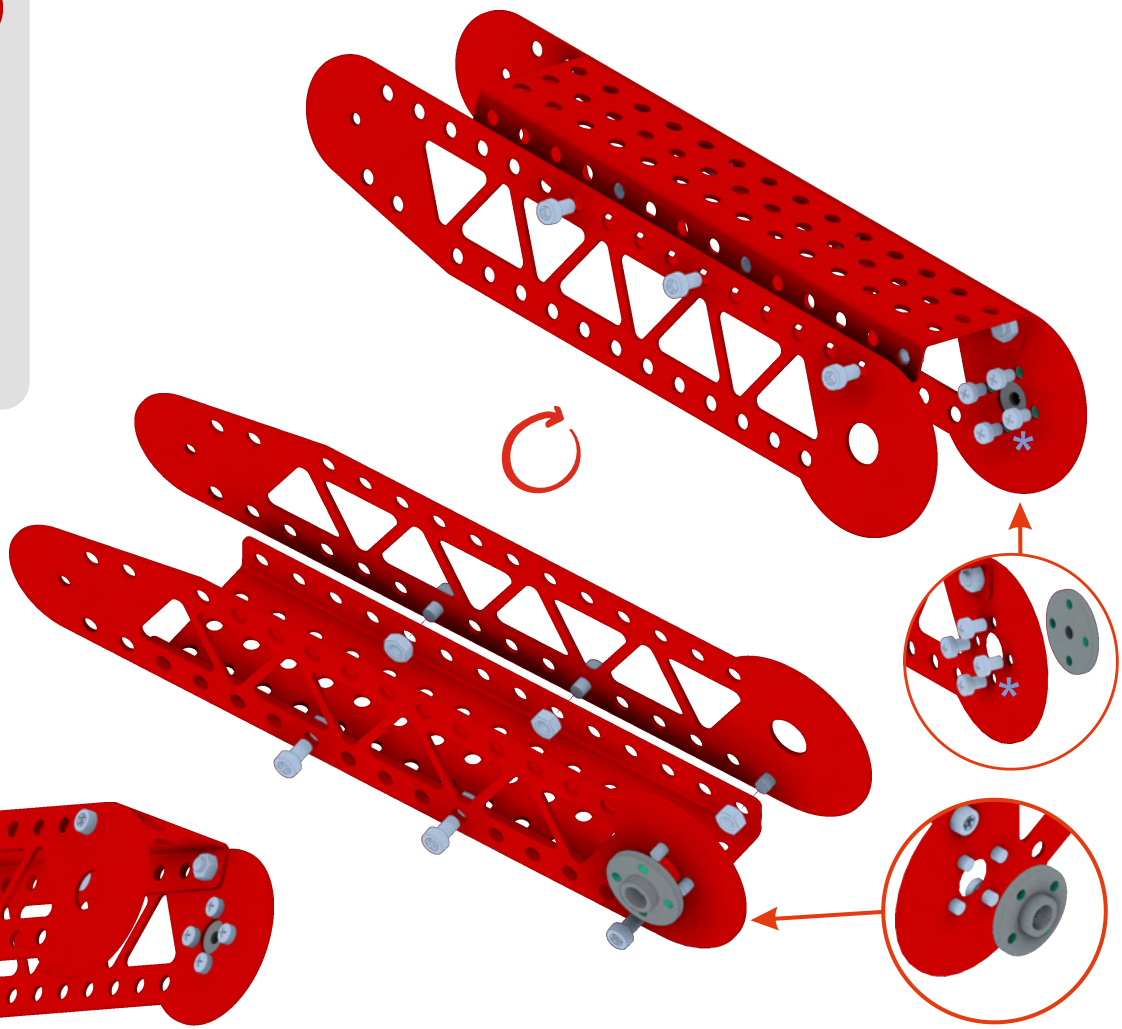
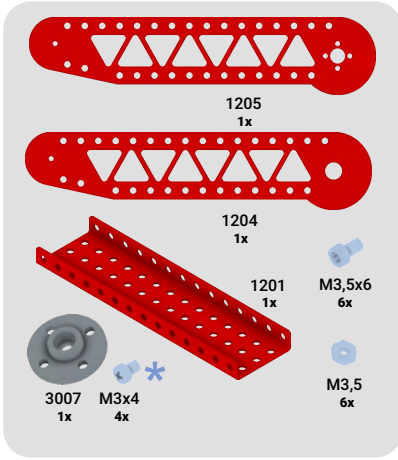

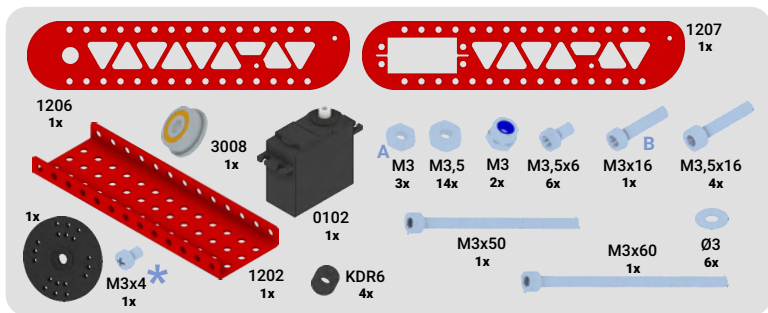
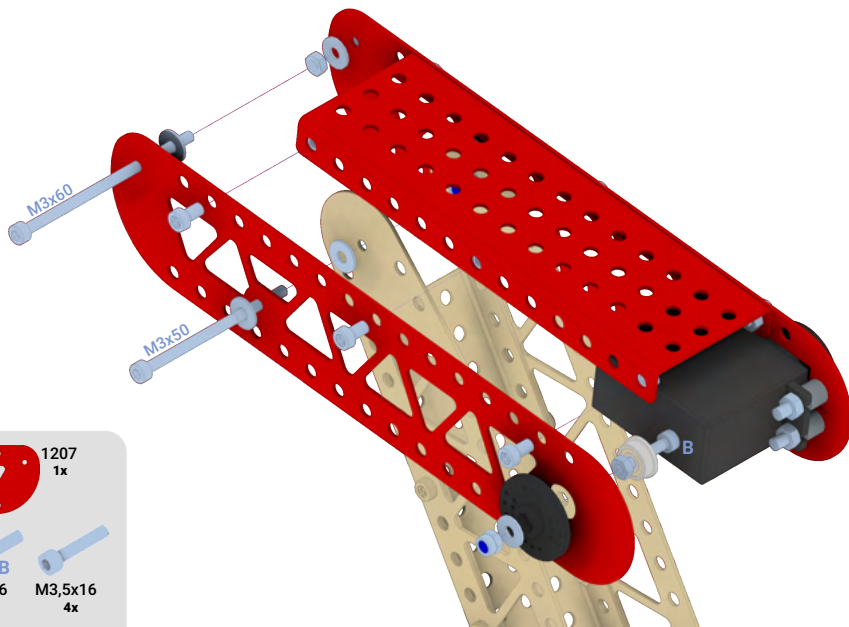
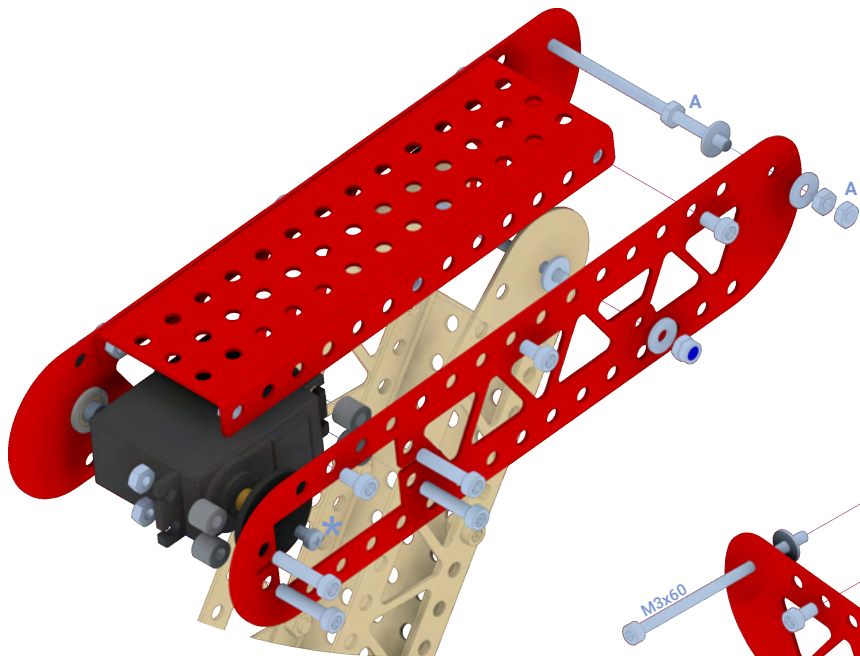

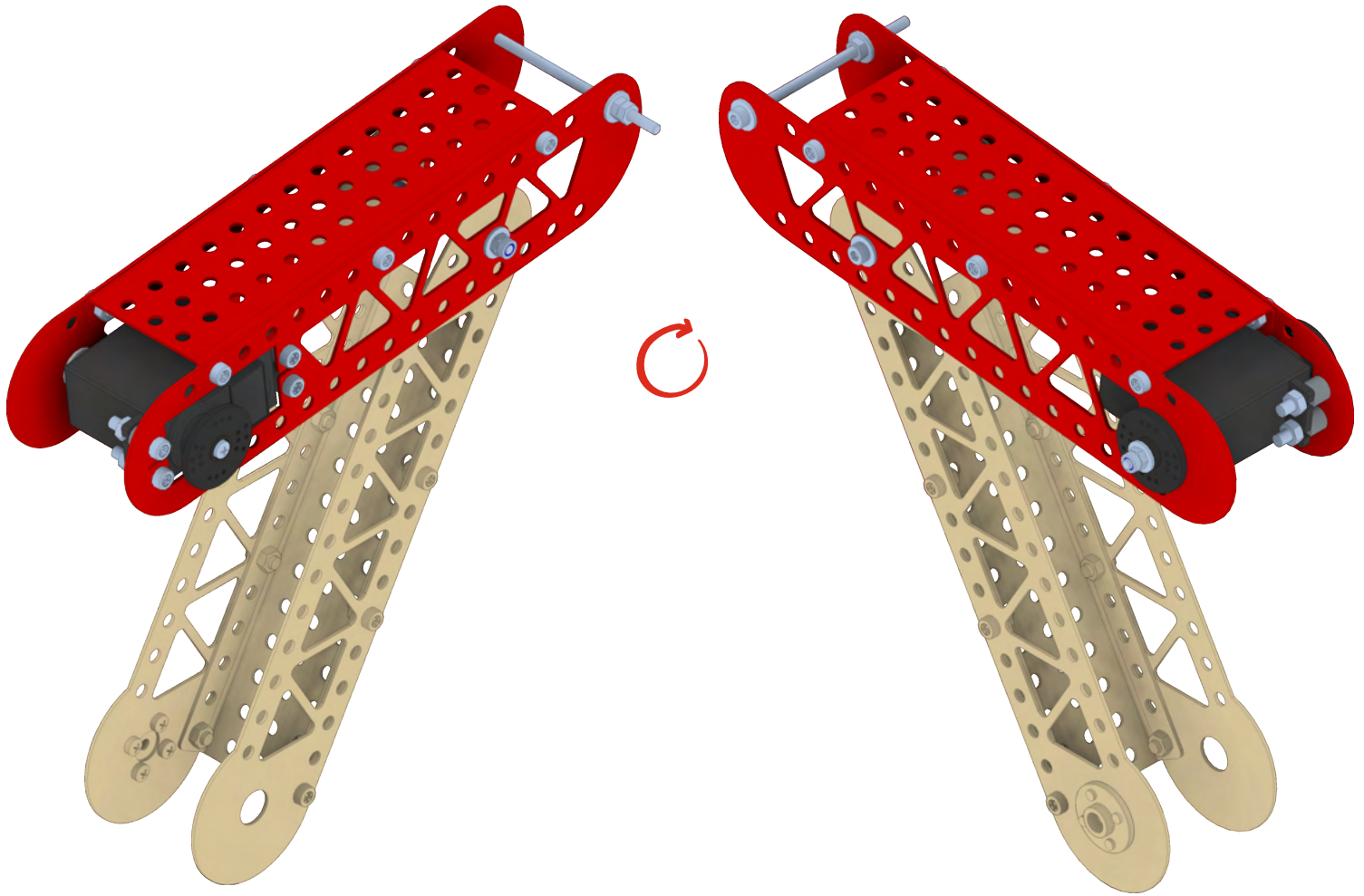

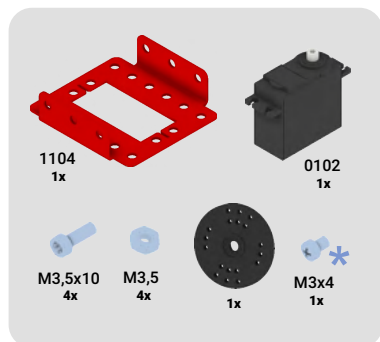
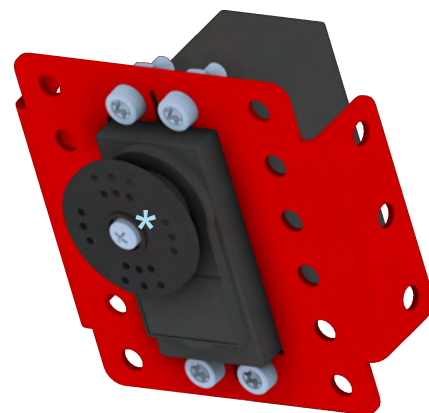
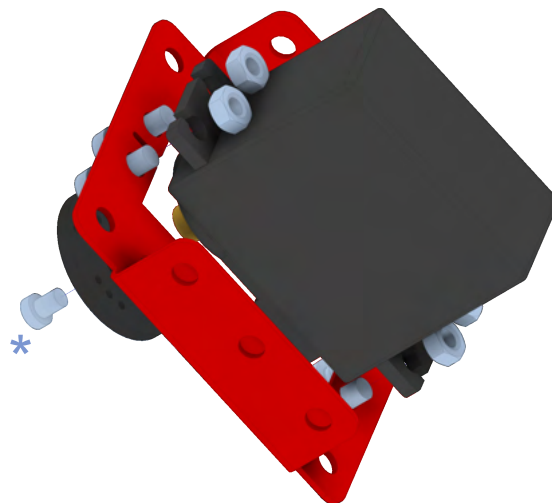
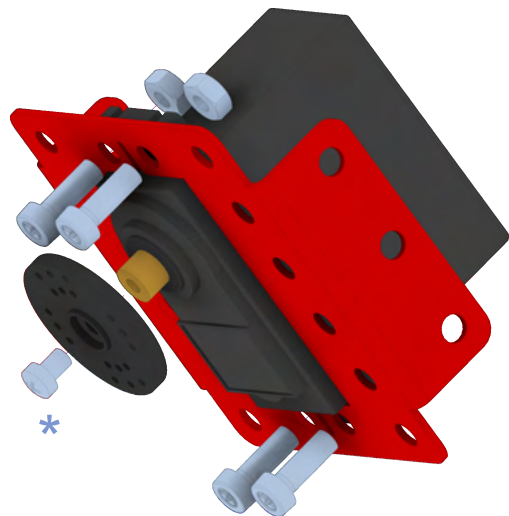

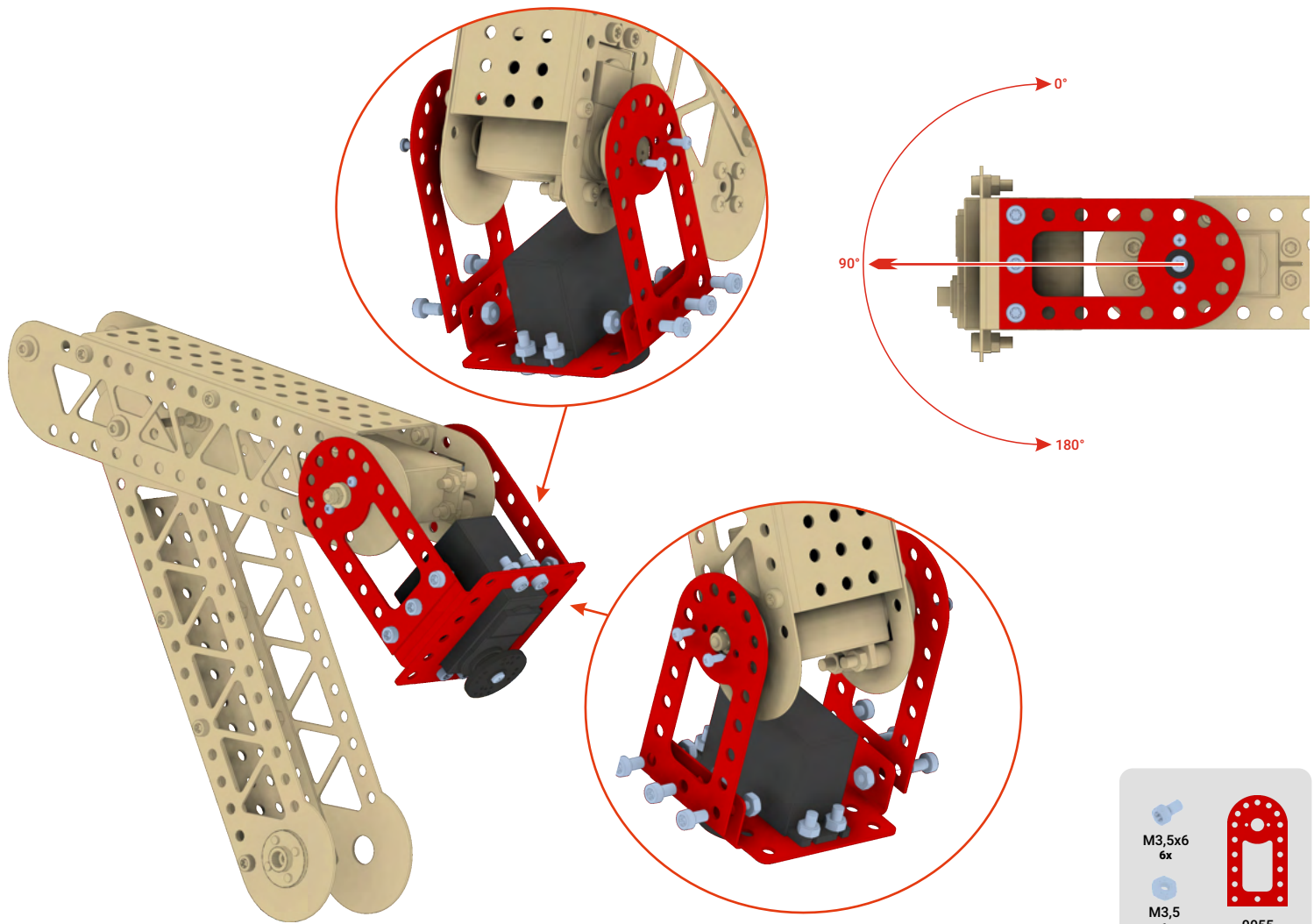





	
M3,5x6 6x	0055 2x
	
M3,5 6x	



M3x4  
1x

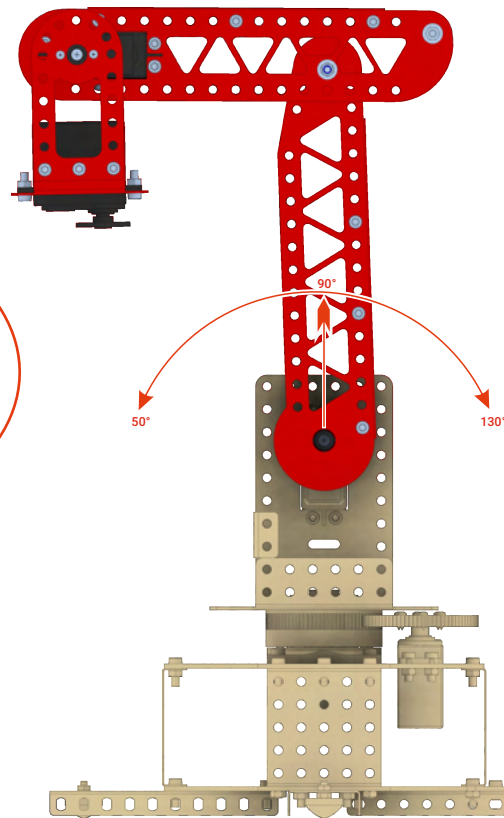
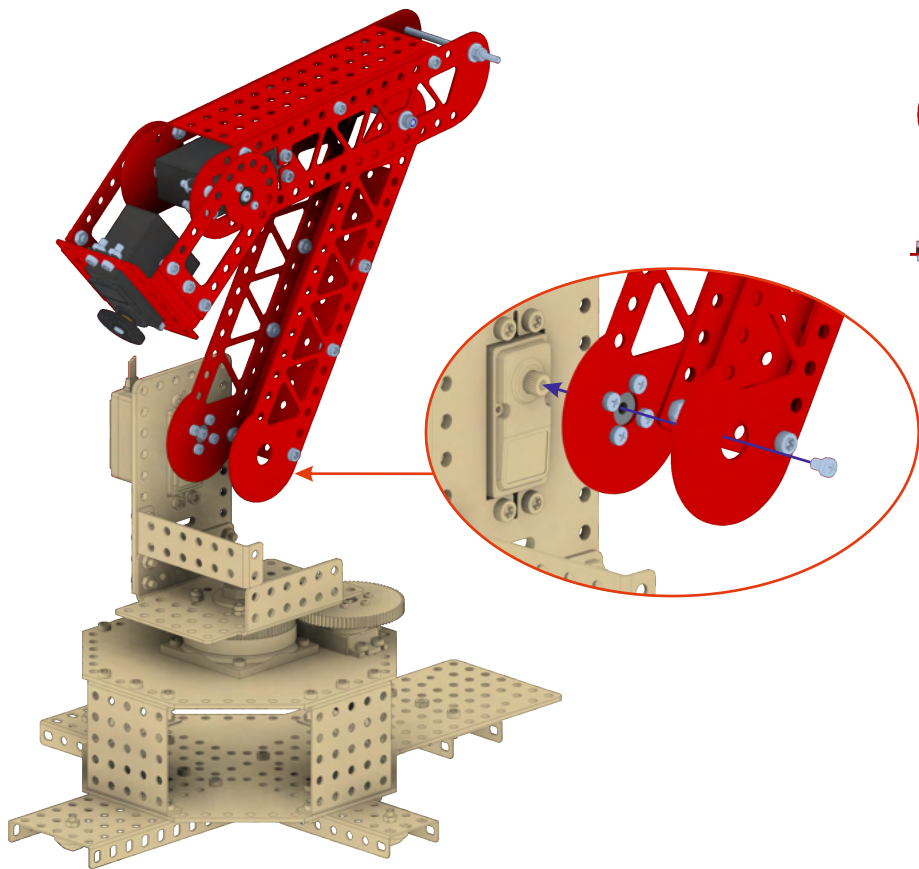

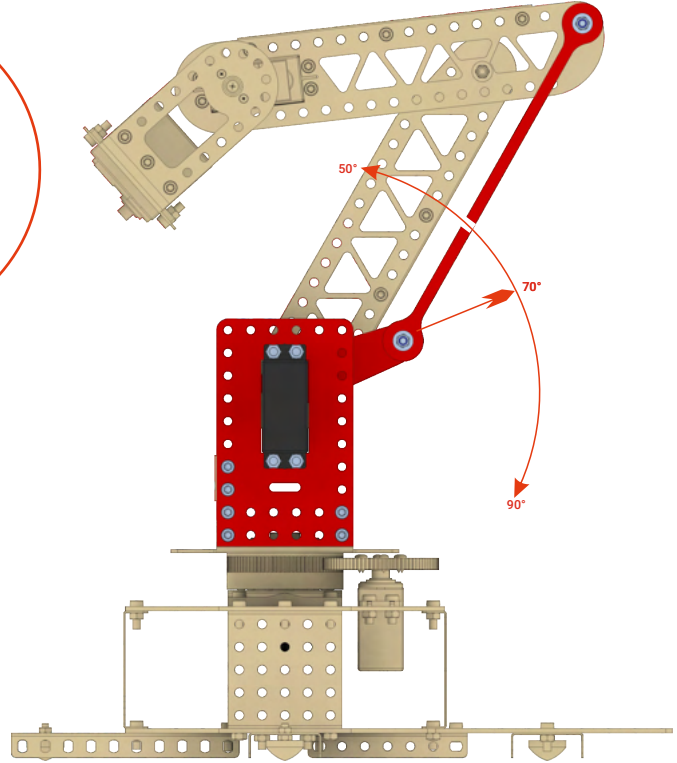
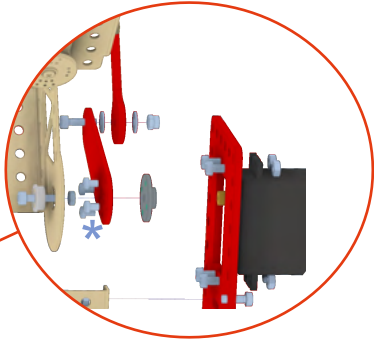
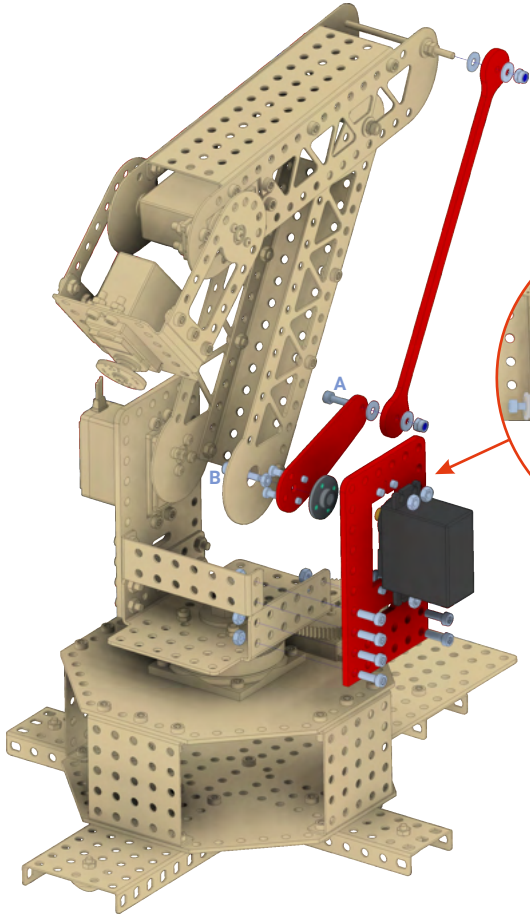
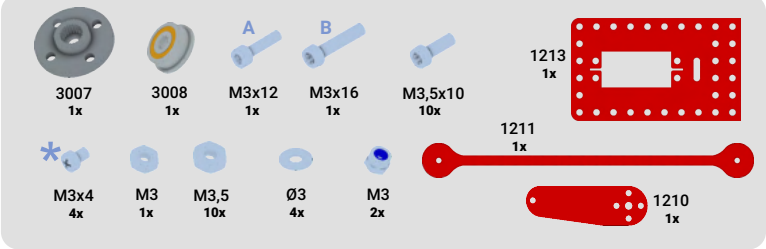

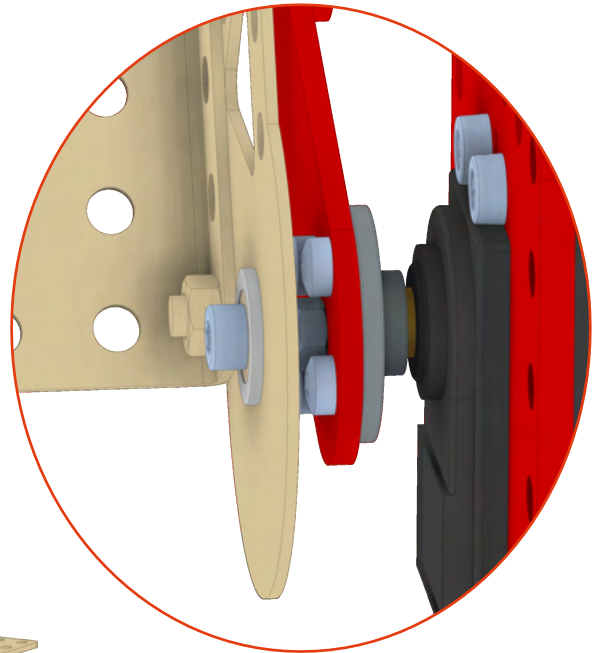
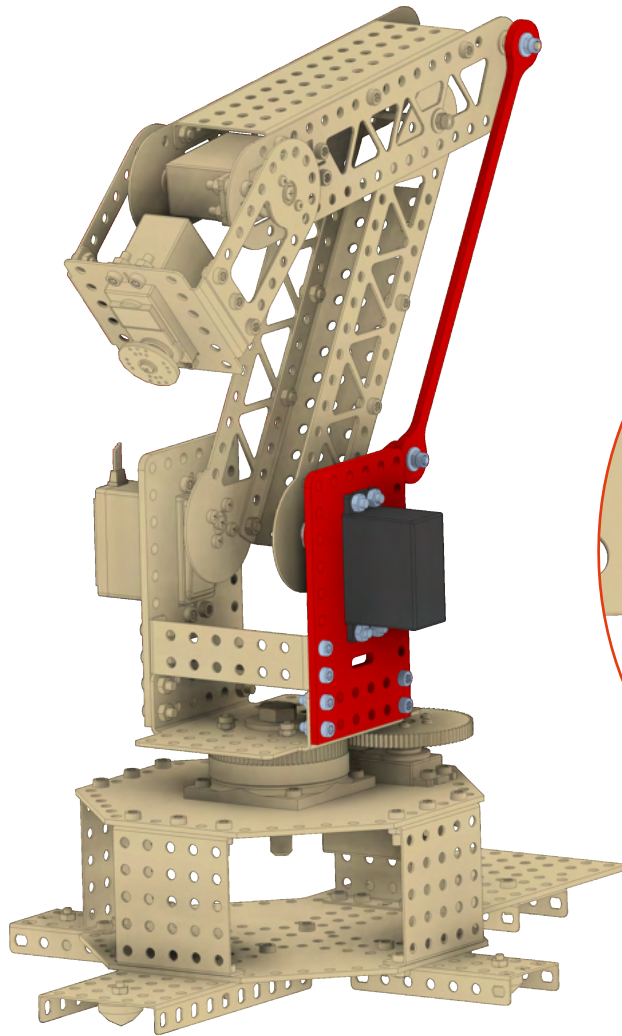

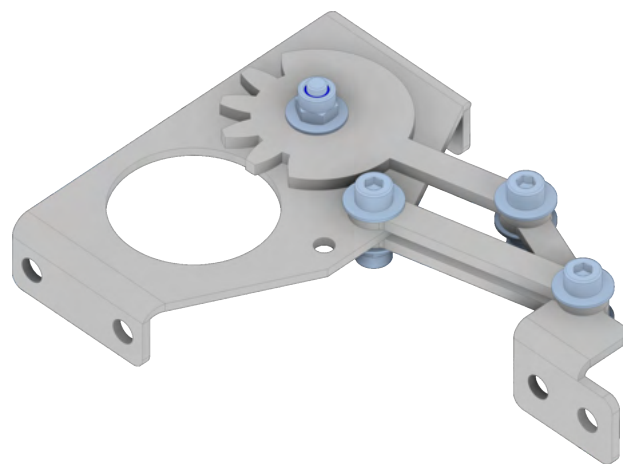
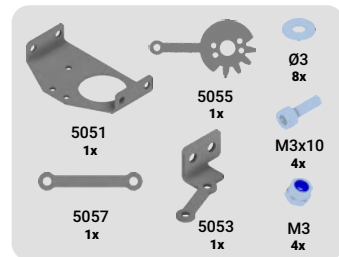
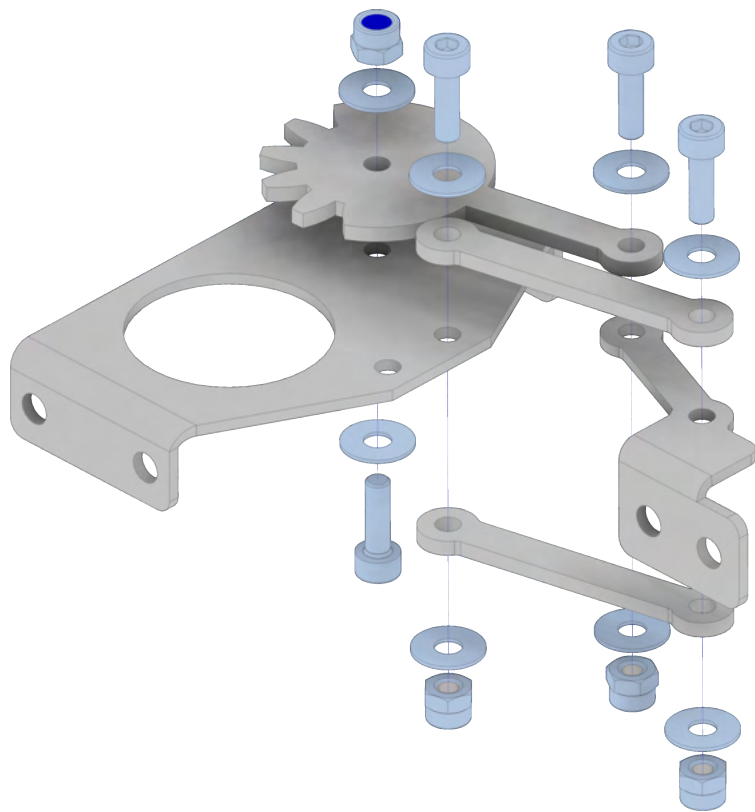

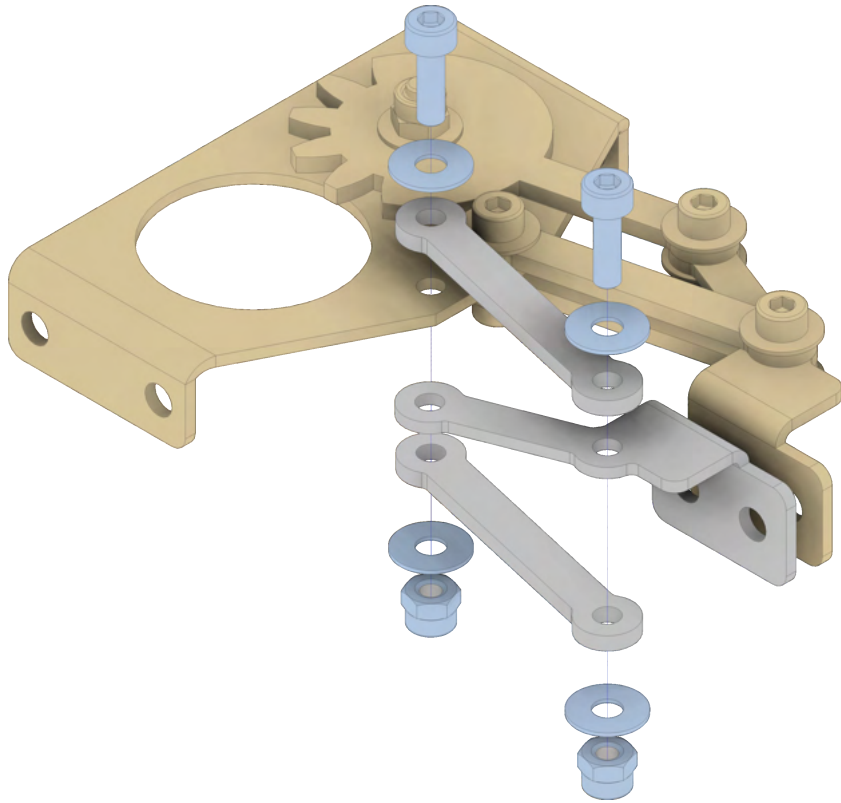





	
5054	Ø3
1x	4x
	
5057	M3x10
1x	2x
	
	M3
	2x

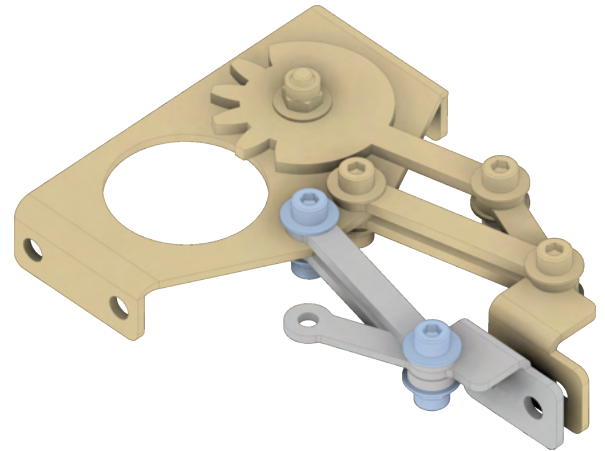

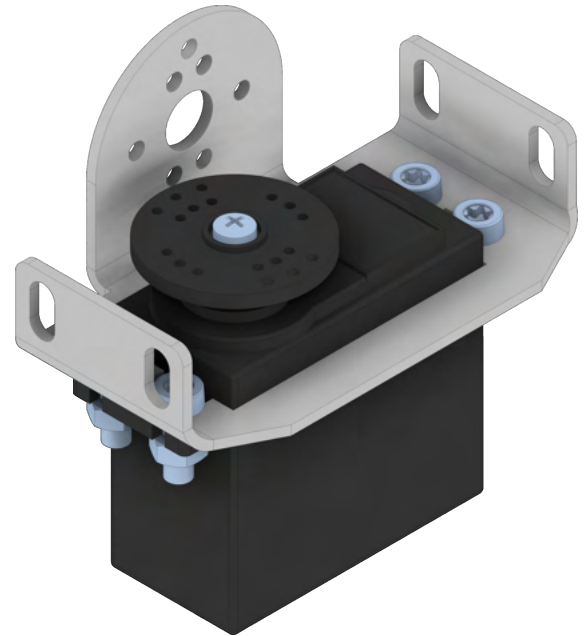
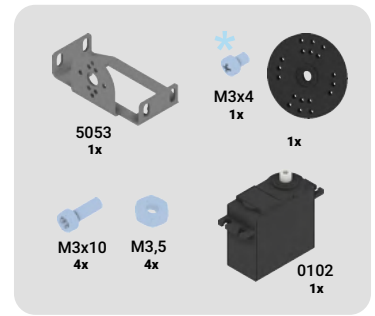
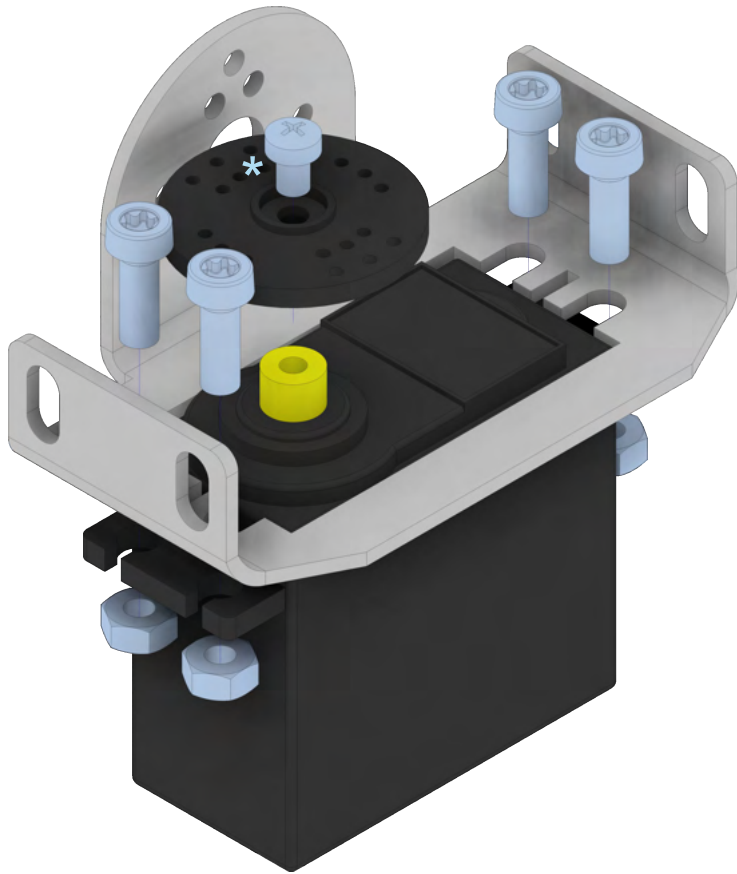

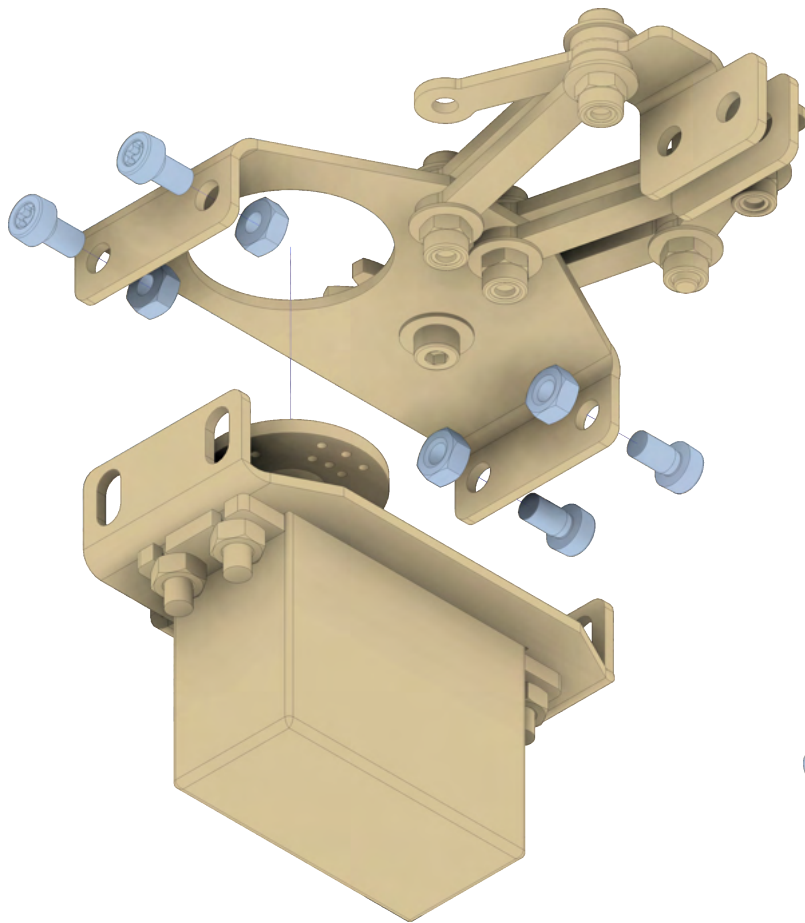





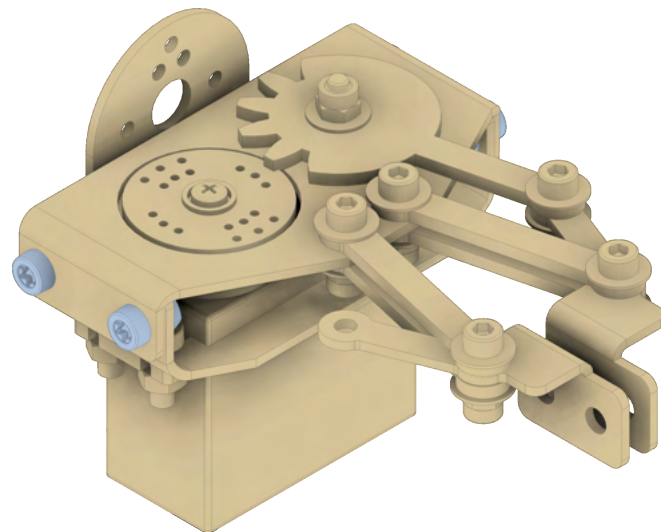

M3,5x6  
4x

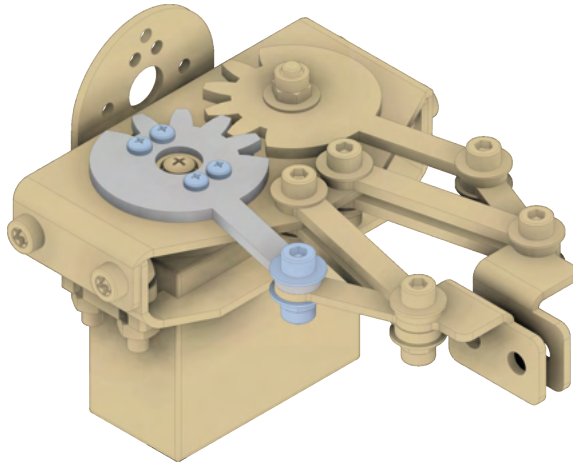
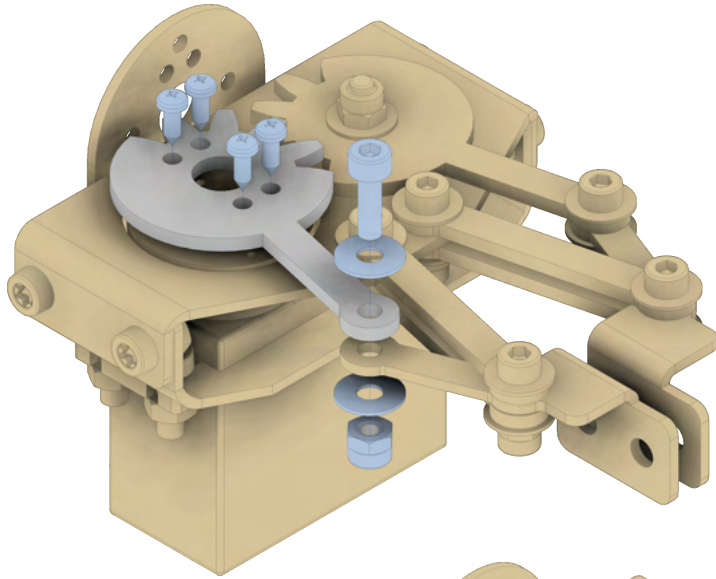

M3,5  
4x



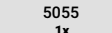

 M3x10 1x	 M2,2x6,5 4x	
 M3,5 1x	 Ø3 2x	
		5055 1x

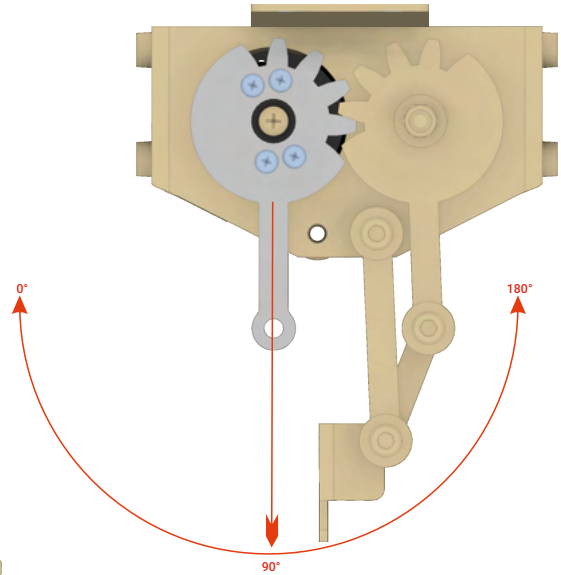



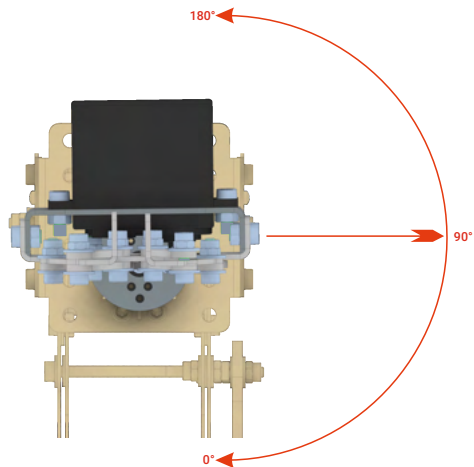
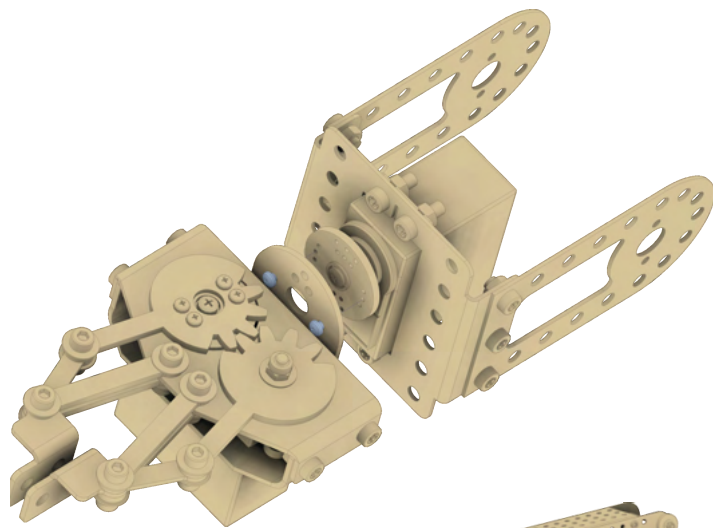
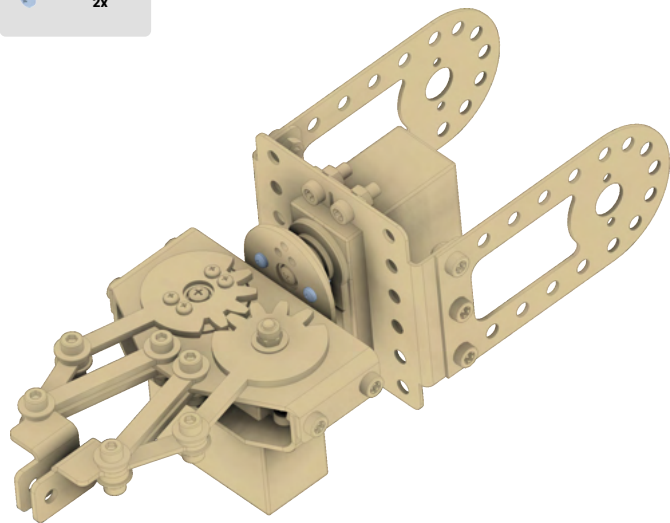

M2,2x6,5  
2x

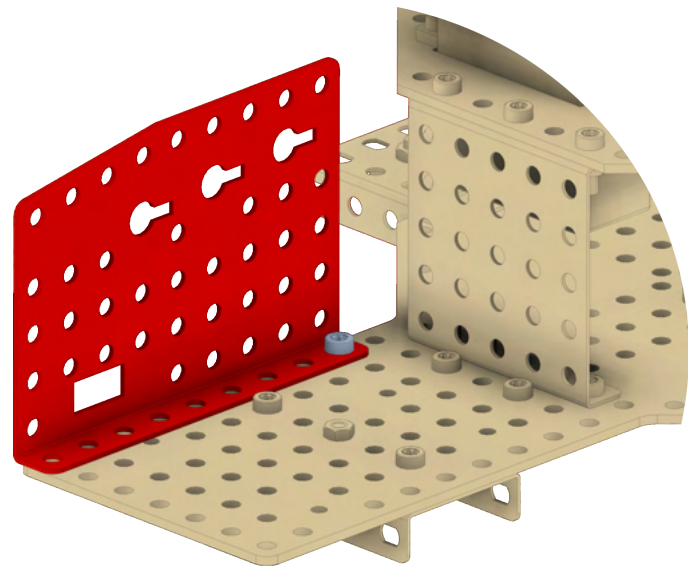
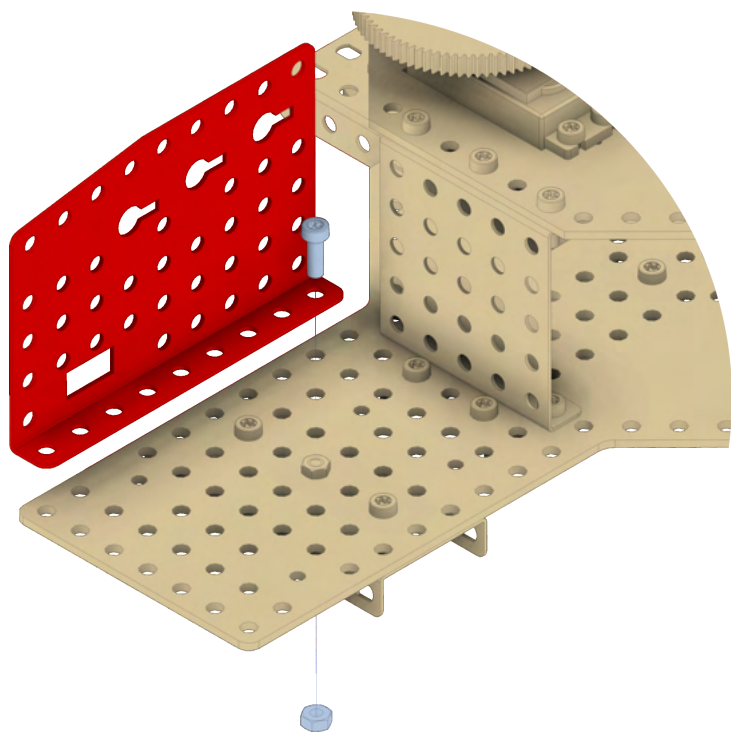

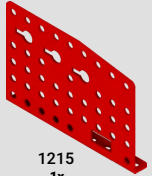

	M3,5x10 1x	
	M3,5 1x	
	1215 1x	

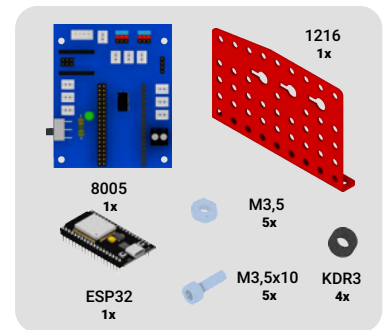
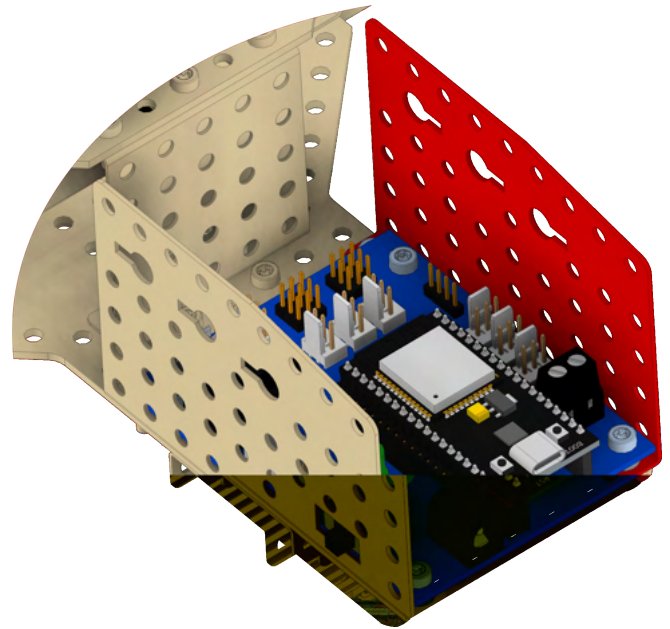
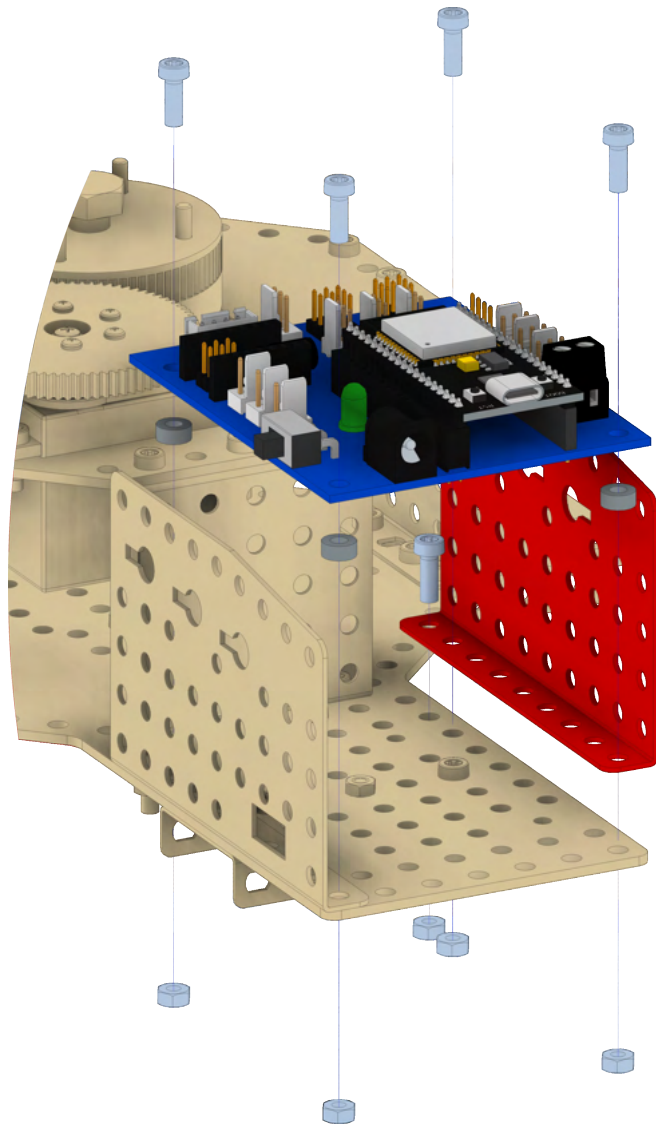

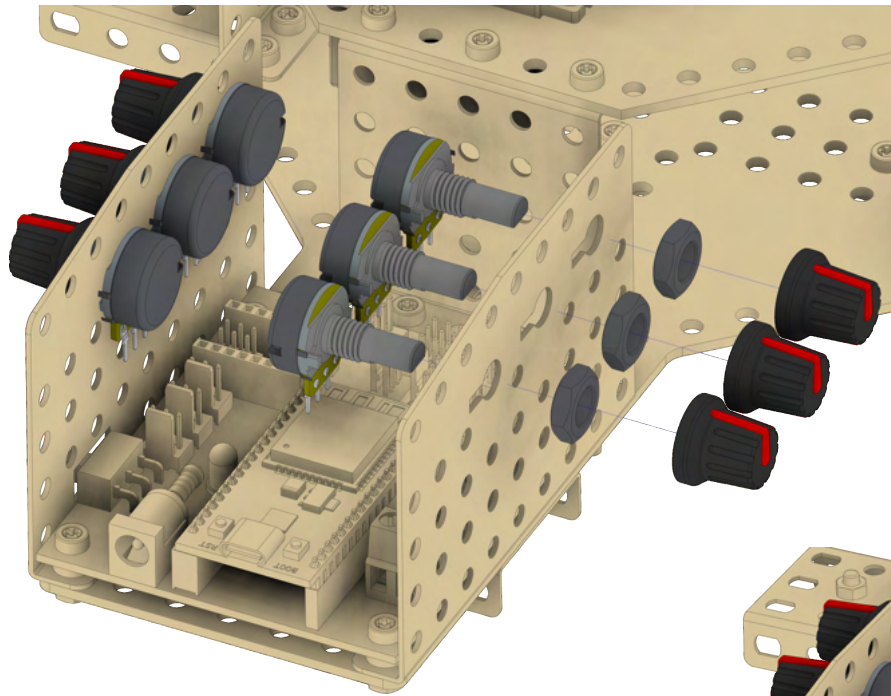

9161a  
6x

9161b  
6x

9161c  
6x

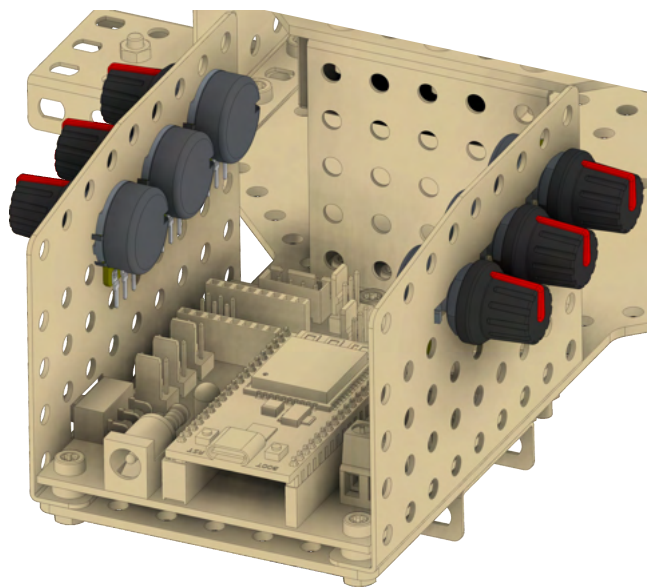
A legend box containing three items: a grey knob with a yellow-green base (9161a), a light blue ring (9161b), and a black knob with a red accent (9161c). Each item is accompanied by its part number and a quantity of 6x.

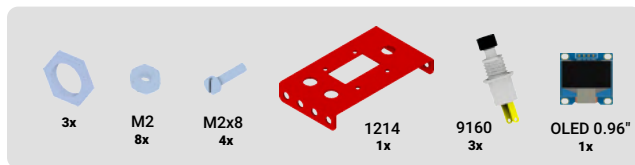
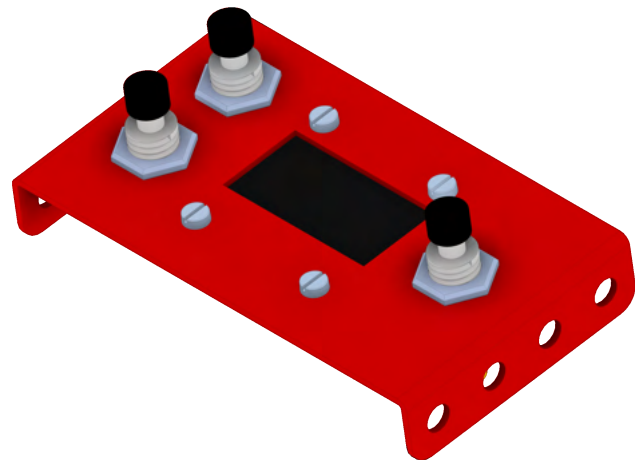
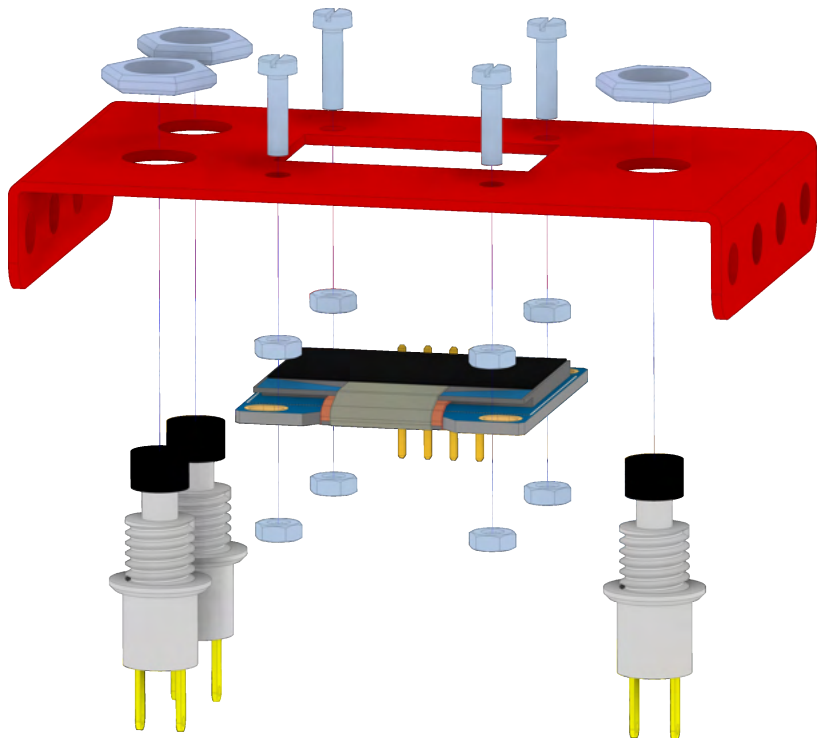

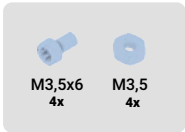
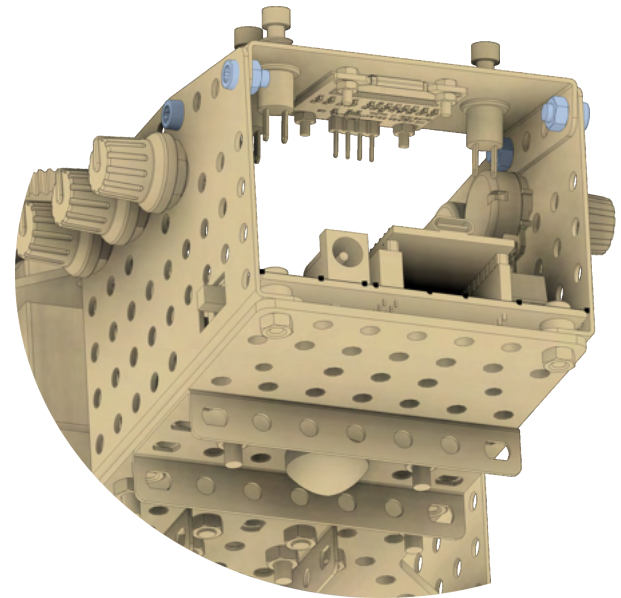
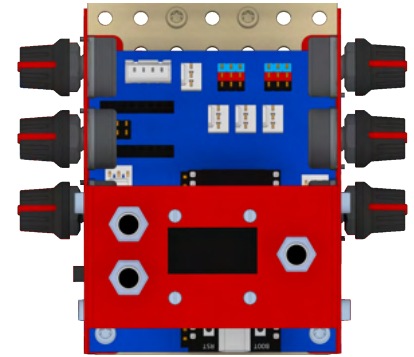
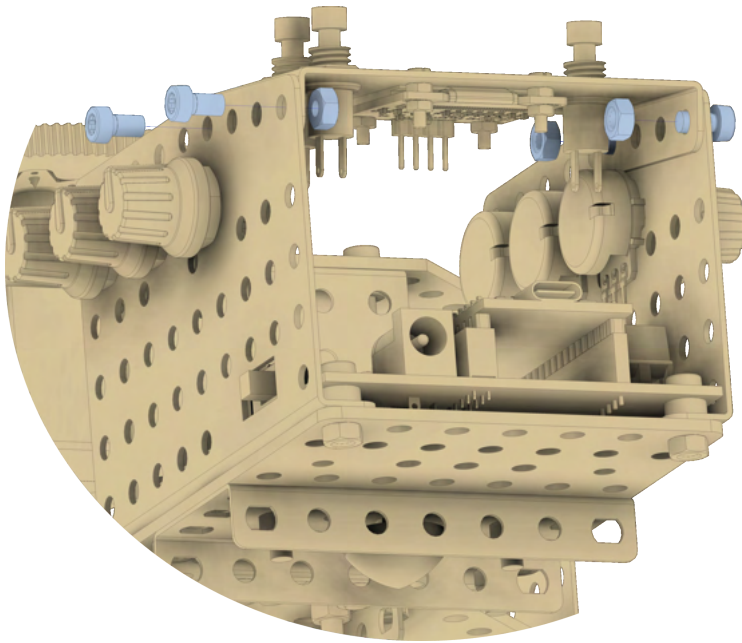

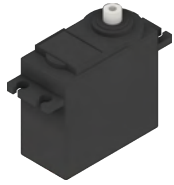

**Z0 → S1**

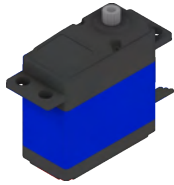

**R0 → S2**

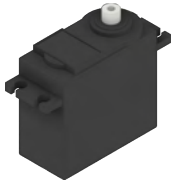

**R1 → S3**

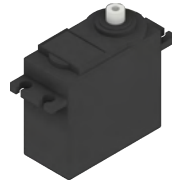

**R2 → S4**

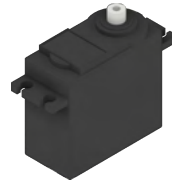

**OC → S5**

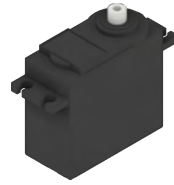

**CH → S6**



30cm



30cm



60cm



60cm



60cm

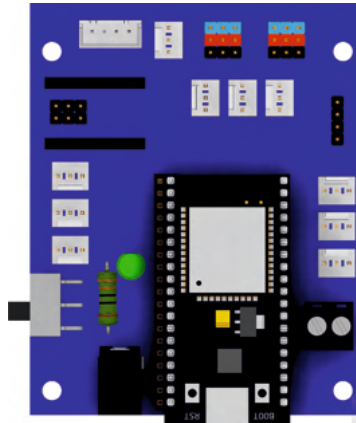

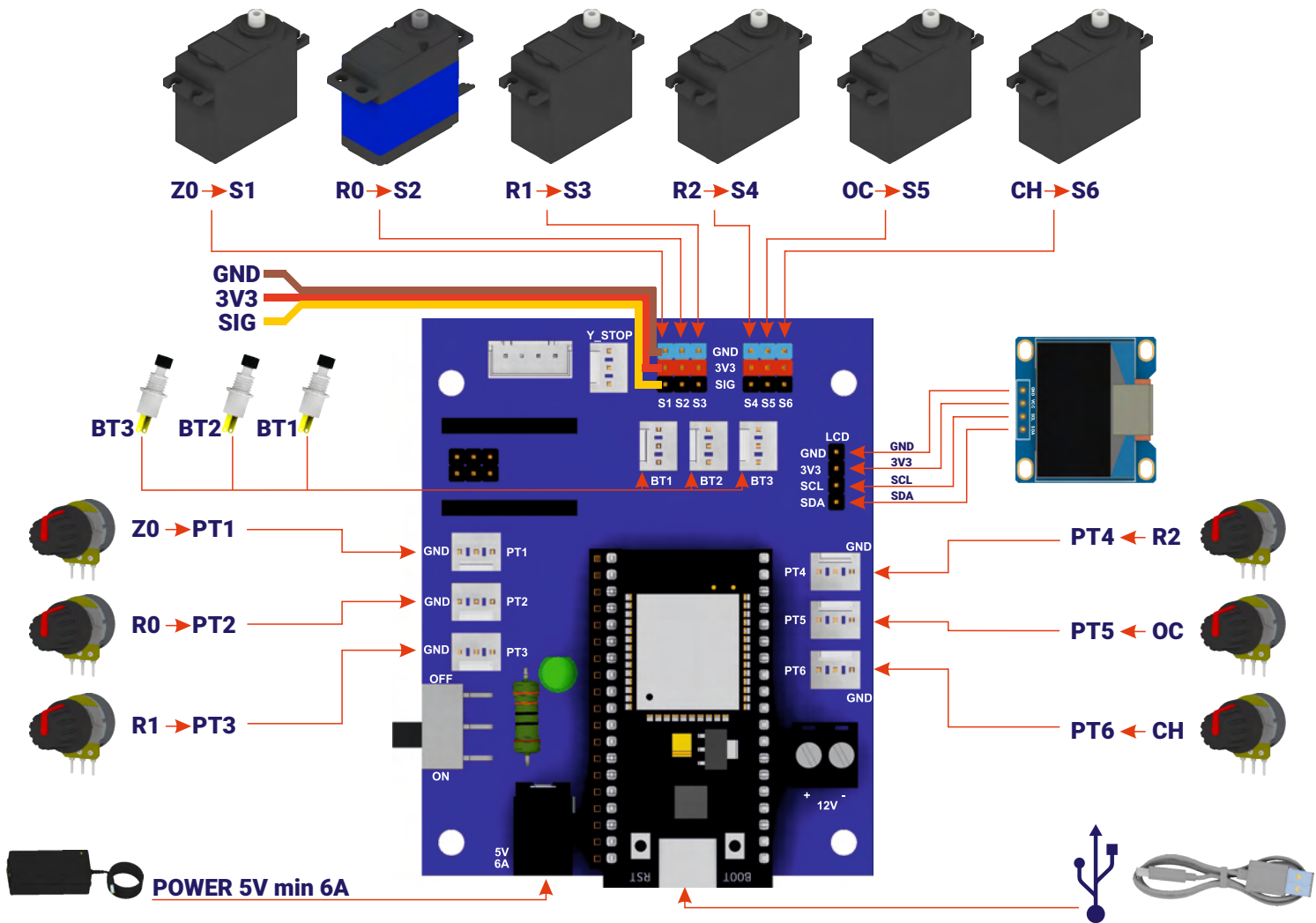

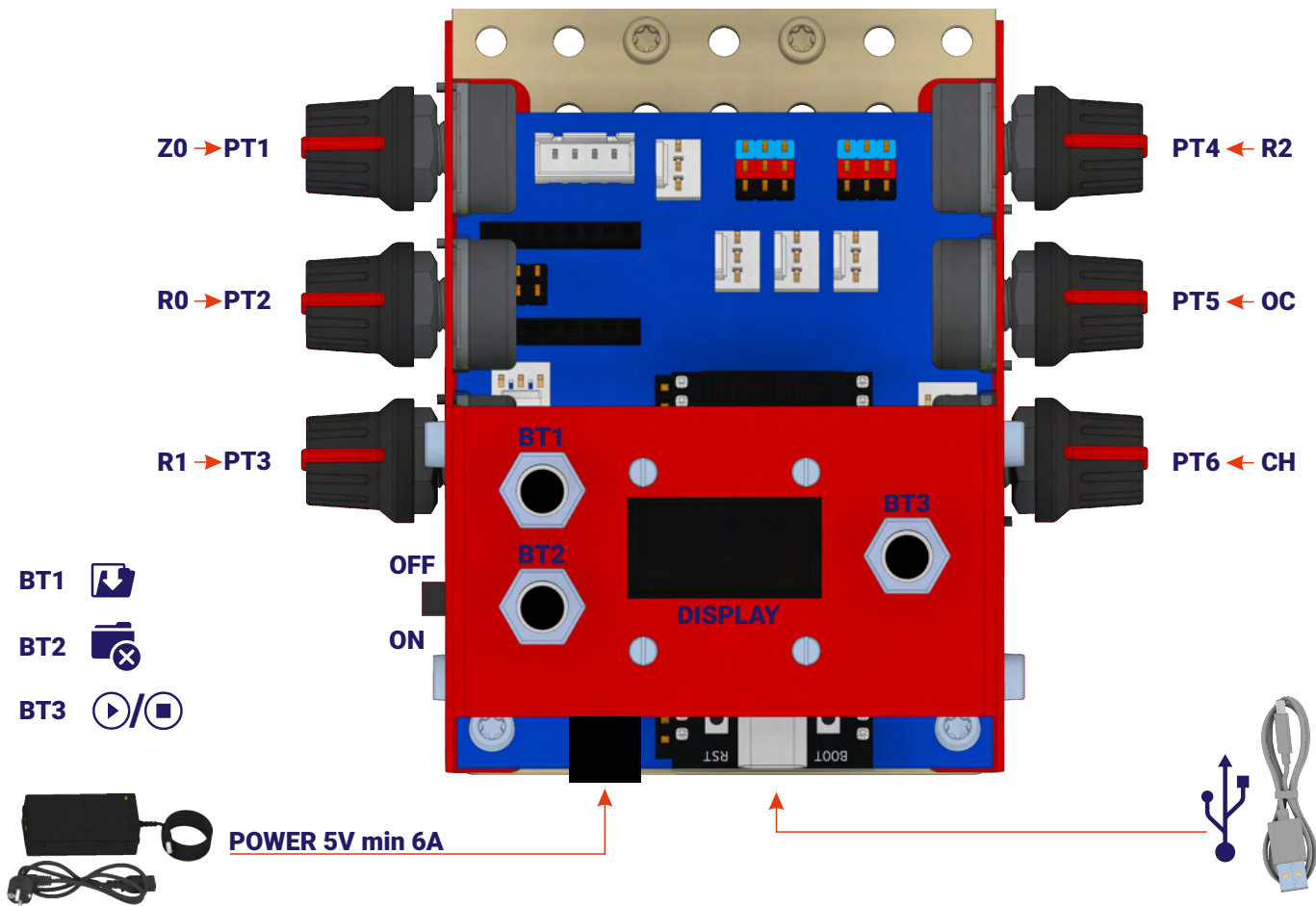

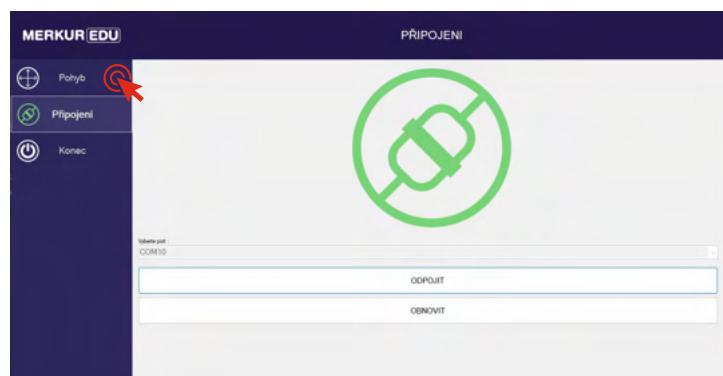
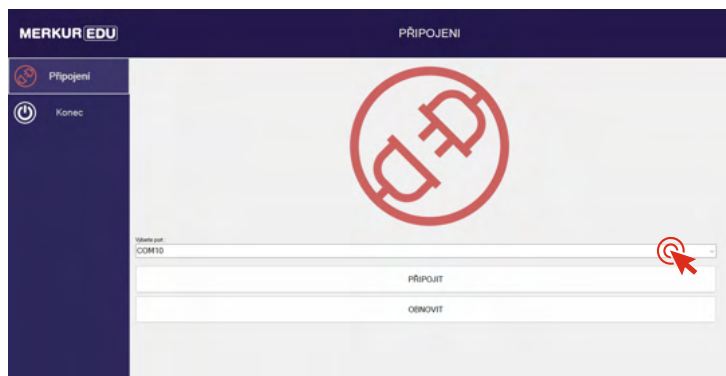
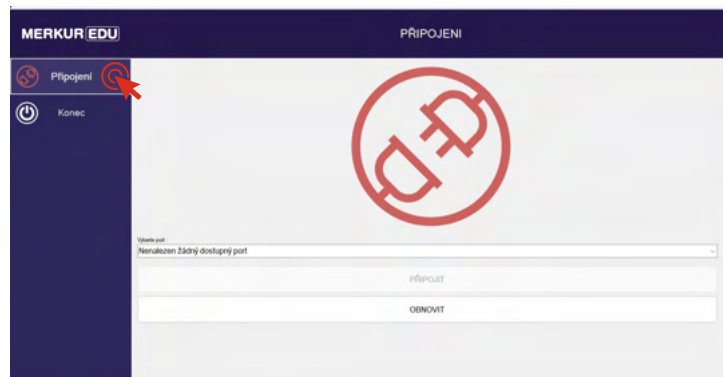
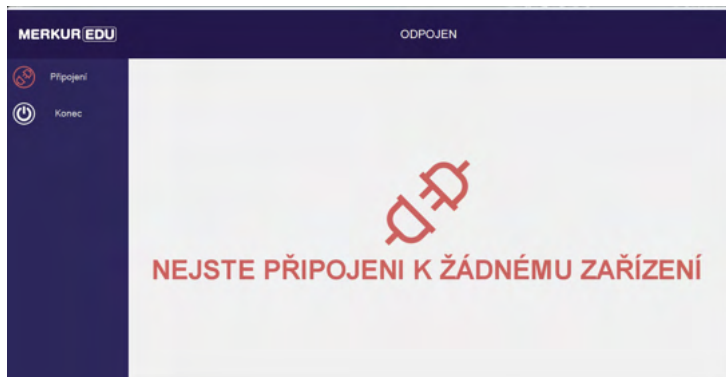



**MERKUR EDU**

**POHYB**

Pohyb  
 Připojení  
 Koniec

	Z0	R0	R1	R2	OC	CH																																																	
	90°	90°	120°	150°	90°	130°																																																	
<table border="1"> <thead> <tr> <th>Poloha</th> <th>Z0</th> <th>R0</th> <th>R1</th> <th>R2</th> <th>OC</th> <th>CH</th> </tr> </thead> <tbody> <tr> <td>1</td> <td>0</td> <td>0</td> <td>0</td> <td>0</td> <td>0</td> <td>0</td> </tr> <tr> <td>2</td> <td>0</td> <td>0</td> <td>0</td> <td>0</td> <td>0</td> <td>0</td> </tr> <tr> <td>3</td> <td>0</td> <td>0</td> <td>0</td> <td>0</td> <td>0</td> <td>0</td> </tr> <tr> <td>4</td> <td>0</td> <td>0</td> <td>0</td> <td>0</td> <td>0</td> <td>0</td> </tr> <tr> <td>5</td> <td>0</td> <td>0</td> <td>0</td> <td>0</td> <td>0</td> <td>0</td> </tr> <tr> <td>6</td> <td>0</td> <td>0</td> <td>0</td> <td>0</td> <td>0</td> <td>0</td> </tr> </tbody> </table>	Poloha	Z0	R0	R1	R2	OC	CH	1	0	0	0	0	0	0	2	0	0	0	0	0	0	3	0	0	0	0	0	0	4	0	0	0	0	0	0	5	0	0	0	0	0	0	6	0	0	0	0	0	0						
Poloha	Z0	R0	R1	R2	OC	CH																																																	
1	0	0	0	0	0	0																																																	
2	0	0	0	0	0	0																																																	
3	0	0	0	0	0	0																																																	
4	0	0	0	0	0	0																																																	
5	0	0	0	0	0	0																																																	
6	0	0	0	0	0	0																																																	
							Načítání...																																																
							Ukládání...																																																
							Posun nahoru																																																
							Posun dolů																																																
							Auto																																																
							Vymazat																																																

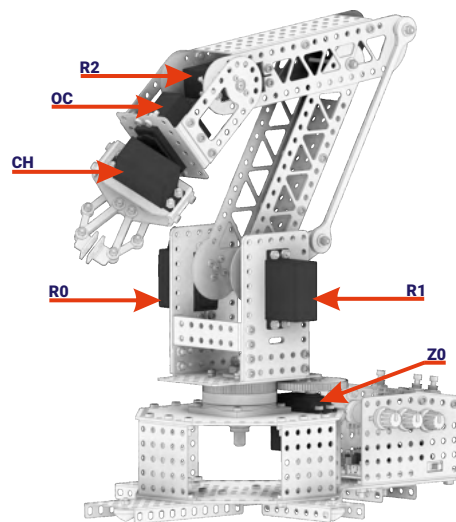

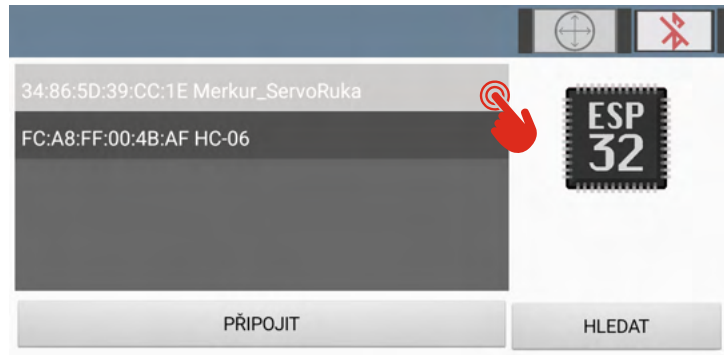
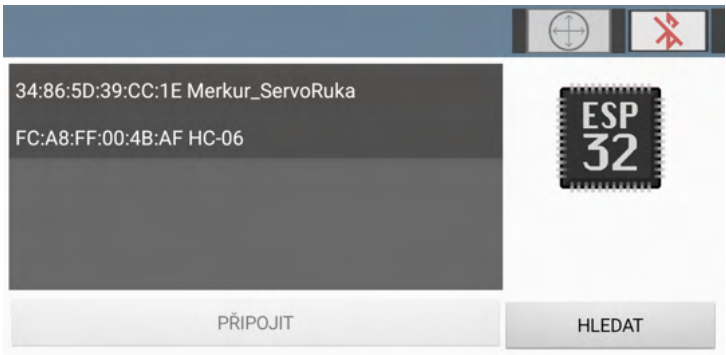
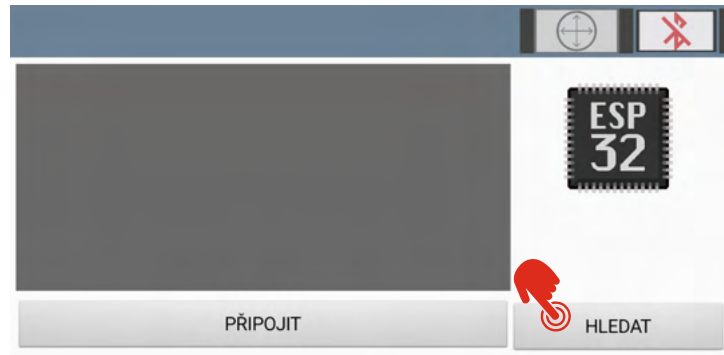
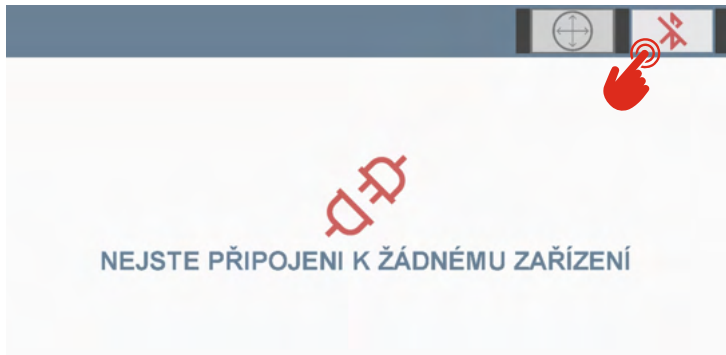

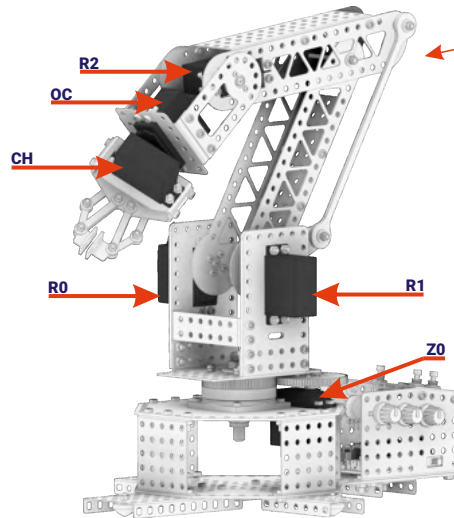
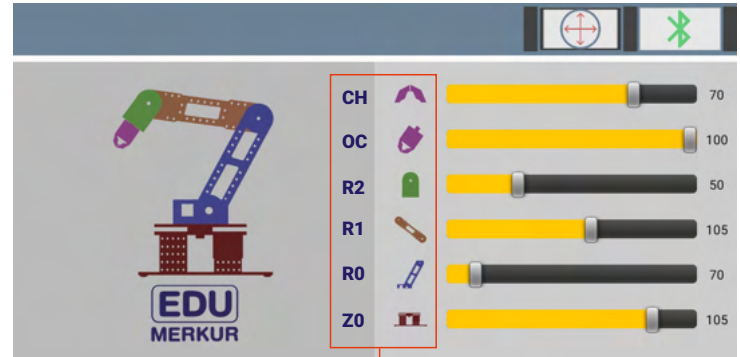



**MERKUR**

STAVÍME S  JIŽ VÍCE NEŽ 100 LET

**MERKUR TOYS s.r.o.** - Police nad Metují - Czech republic - [www.merkurtoys.cz](http://www.merkurtoys.cz) <https://navody.merkurtoys.cz>